



CELEBRATING
25 YEARS
OF TRUST &
INNOVATION

Aquarius[®]

LEAD-FREE POTABLE WATER
TRANSPORT SOLUTIONS

PRODUCT CATALOGUE

An aerial photograph of a city, likely New York City, with a large, white, semi-transparent pipe graphic overlaid. The pipe is positioned diagonally across the frame, with its open end on the left, overlooking a river. The city buildings and streets are visible through the pipe's opening and in the background. The sky is blue with some light clouds.

**ASTRAL
Aquarius**

CONTENTS



03

ABOUT ASTRAL

04

INNOVATION &
RECOGNITIONS

05

MARKETING
NETWORK

06

LEADING THE
LEAD-FREE PIPE
MOVEMENT

08

ABOUT AQUARIUS

09

THE DIFFERENCE
BETWEEN
uPVC & PVC

09

PVC - POLYVINYL
CHLORIDE

10

BENEFITS OF ASTRAL
AQUARIUS SYSTEM
OVER OTHER uPVC
SYSTEMS

11

CERTIFICATES
& APPROVALS

12

STANDARDS &
SPECIFICATIONS

13

IMPORTANT FOR
INSTALLERS & USERS

14

KEY
PROPERTIES

15

FIELDS OF
APPLICATIONS

16

PRESSURE PIPES
AND FITTINGS

17

PVC SCHEDULE 40
AND SCHEDULE 80
FITTINGS

18

BASIC SOCKET
DIMENSIONS

19

PRODUCT
RANGE

38

FRICTION LOSS
TABLE

40

EXPANSION AND
CONTRACTION OF
uPVC PIPE

42

JOINT CURING &
SUPPORT SPACING
FOR uPVC PIPE

44

INSTALLATION
PROCEDURE

46

TESTING
PRESSURE SYSTEM

47

UNDERGROUND
INSTALLATION

49

HANDLING
AND STORAGE

50

FREQUENTLY ASKED
QUESTIONS (FAQs)

1st TO
INTRODUCE
CPVC
IN INDIA

1st TO
INTRODUCE
UPVC LEAD
FREE PIPES
IN INDIA

1st TO
INTRODUCE
LOW NOISE
PP DRAINAGE
PIPES IN INDIA

1st TO
INTRODUCE
FOAMED PVC
DRAINAGE
PIPES IN INDIA

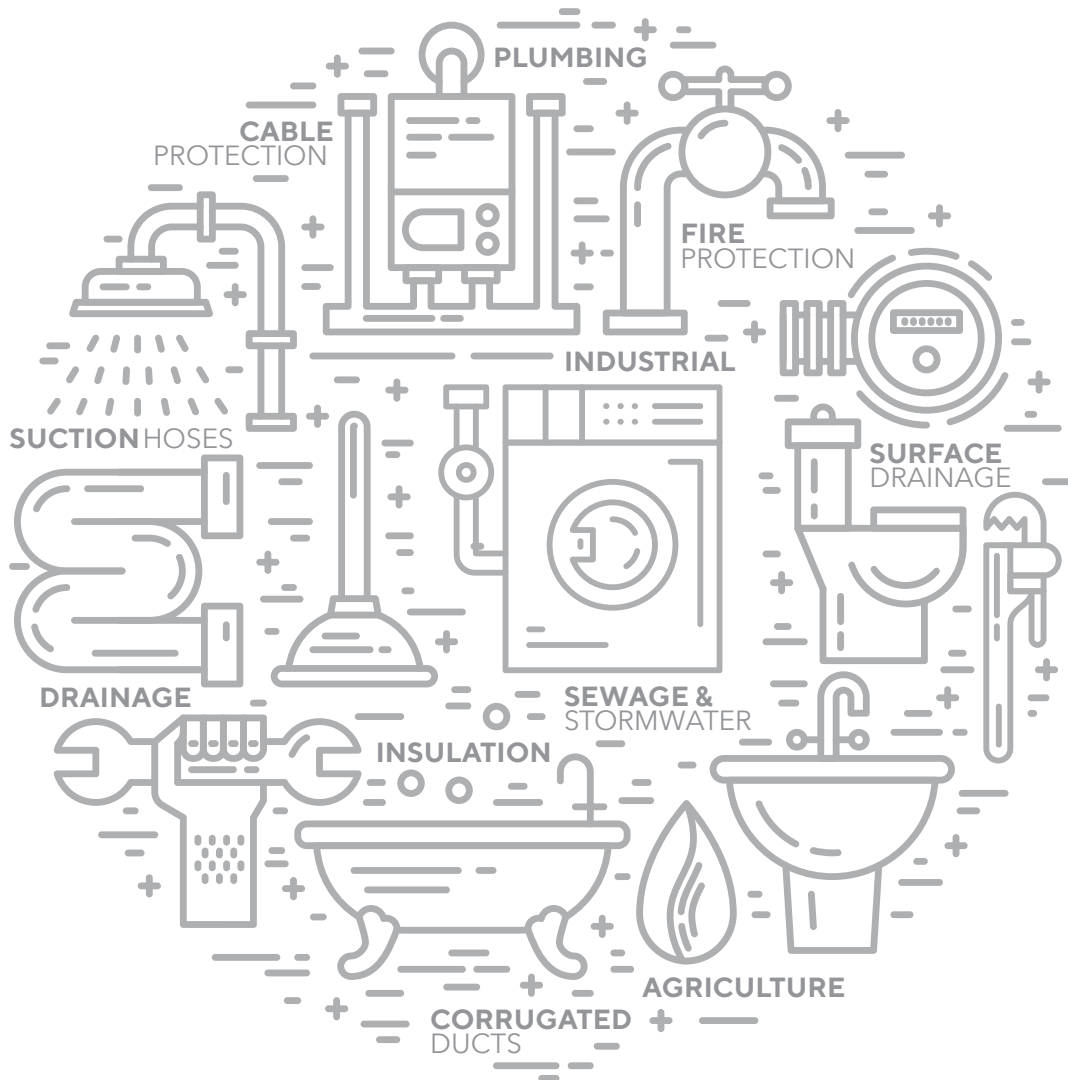

1st TO
INTRODUCE
LEAD FREE
COLUMN PIPES
IN INDIA

1st TO
INTRODUCE
POLYMER BASED
INDUSTRIAL
PIPING SYSTEM
IN INDIA

1st TO
INTRODUCE
NSF APPROVED
SOLVENT
CEMENT
IN INDIA

1st TO
INTRODUCE
CPVC PIPING FOR
AUTOMATIC
FIRE SPRINKLER
SYSTEM IN INDIA

ASTRAL, INDIA'S PROGRESSIVE BUILDING MATERIALS COMPANY

Established in 1996 with the aim to manufacture best-in-globe plastic piping systems, Astral Pipes fulfils emerging piping needs of millions of houses and adds extra mileage to India's developing real estate fraternity with the hallmark of unbeaten quality and innovative piping solutions. Keeping itself ahead of the technology curve, Astral has always been a front runner in the piping category by bringing innovation and getting rid of old, primitive and ineffective plumbing methods. Bringing CPVC in India, and pioneering in this technology, have set Astral apart and its highest quality enabled it to obtain NSF approval for its CPVC pipes and fittings. Astral went beyond the category codes by launching many industry firsts, like launching India's first lead-free uPVC pipes for plumbing as well as for stream water, just to name a few.

Astral Pipes offers the widest product range across this category when it comes to product applications. Astral Pipes is equipped with production facilities at Santej and Dholka in Gujarat, Hosur in Tamil Nadu, Ghiloth in Rajasthan, Sangli & Aurangabad in Maharashtra, Cuttack in Odisha and Sitarganj in Uttarakhand to manufacture plumbing systems, drainage systems, agriculture systems, fire sprinkler piping systems, industrial piping and electrical conduit pipes with all kinds of necessary fittings.

Astral Pipes' Infrastructure division offers a comprehensive product range including corrugated piping for drainage and cables, polyolefin cable channels, sewage treatment plants, plastic sheathing ducts, suction hoses, and sub-surface drainage systems. This range helps Astral to establish a strong foothold in infrastructure and agriculture sector in the constantly evolving business of piping.

In 2014, Astral forayed into the adhesives category by acquiring UK-based Seal It Services Ltd. and Kanpur based Resinova Chemie Ltd., which manufacture adhesives, sealants and construction chemicals. With five manufacturing facilities now in this business segment, Astral has strengthened its presence in the category and made rapid inroads.

In the year 2020, Astral has expanded its product portfolio and entered into the Water Tanks Segment. The water tank segment is an expanded domain of plumbing and water supply with a huge nationwide potential. Astral Pipes manufactures water tanks from its Santej, Aurangabad, Cuttack, Hosur & Ghiloth manufacturing facilities. A wide range of water storage tanks has helped Astral to become a versatile player in the industry.

Extending the product portfolio further, in the year 2022 Astral forayed into the categories of Faucets and Sanitaryware, followed by acquisition of Bangalore based Gem Paints to enter in the Paints category. This expansion will help Astral march firmly towards becoming a holistic building materials company.

ADHESIVES

EPOXY ADHESIVES & PUTTY
SILICONE SEALANTS
CONSTRUCTION CHEMICALS **PVA**
CYANOACRYLATE **SOLVENT CEMENTS**
TAPES **POLYMERIC FILLING COMPOUND**
ANAEROBIC ADHESIVES
INDUSTRIAL ADHESIVES
INSTANT HAND SANITIZER
SURFACE CLEANING PRODUCTS

PIPING

PLUMBING PIPES & FITTINGS
CPVC, PVC & PEX
SEWERAGE DRAINAGE PIPES & FITTINGS
AGRICULTURE PIPES & FITTINGS
INDUSTRIAL PIPES & FITTINGS
FIRE SPRINKLERS PIPES & FITTINGS
CONDUIT & CABLE PROTECTION
ANCILLARY PRODUCTS
URBAN INFRASTRUCTURE

WATER TANKS

PAINTS

DUCTING

FAUCETS

SANITARYWARE





INNOVATION & RECOGNITIONS

- First to introduce CPVC piping system in India (1999)
- First to launch lead free uPVC piping system in India (2004)
- Corp Excel- National SME Excellence Award (2006)
- First to get NSF Certification for CPVC piping system in India (2007)
- First to launch lead-free uPVC column pipes in India (2012)
- Enterprising Entrepreneur of the year (2012-13)
- Business Standard Star SME of the year (2013)
- Inc. India Innovative 100 for Smart Innovation under category of 'Technology' (2013)
- India's Most Promising Brand Award (2014)
- Value Creator Award during the first ever Fortune India Next 500 (2015)
- India's Most Trusted Pipe Brand Award (2016, 2019, 2020 & 2022)
- ET Inspiring Business Leaders of India Award (2016)
- India's Most Attractive Pipe Brand Award (2016)
- Fortune India 500 Company (2016)
- India's Most Desired Pipe Brand Award (2022)
- Consumer Validated Superbrands India (2017, 2019 & 2021-2022)



MARKETING NETWORK

Astral has a marketing network of more than 800 distributors and 30,000 dealers spread all over India with branch offices at Mumbai, Pune, Delhi, Bengaluru, Chennai, Hyderabad, Jaipur, Lucknow and Kochi. Apart from that Astral has its own warehouses at Vijaywada, Hyderabad, Delhi, Kolhapur, Kolkata, Nagpur, Indore, Patna, Varanasi, Jaipur, Hosur & Guwahati to deliver the material as quick as possible. More than 400 techno marketing professionals and administrative personnel are on the board to coordinate with architects, plumbing contractors and plumbers to utilize the best plumbing techniques and to get the best from the products.

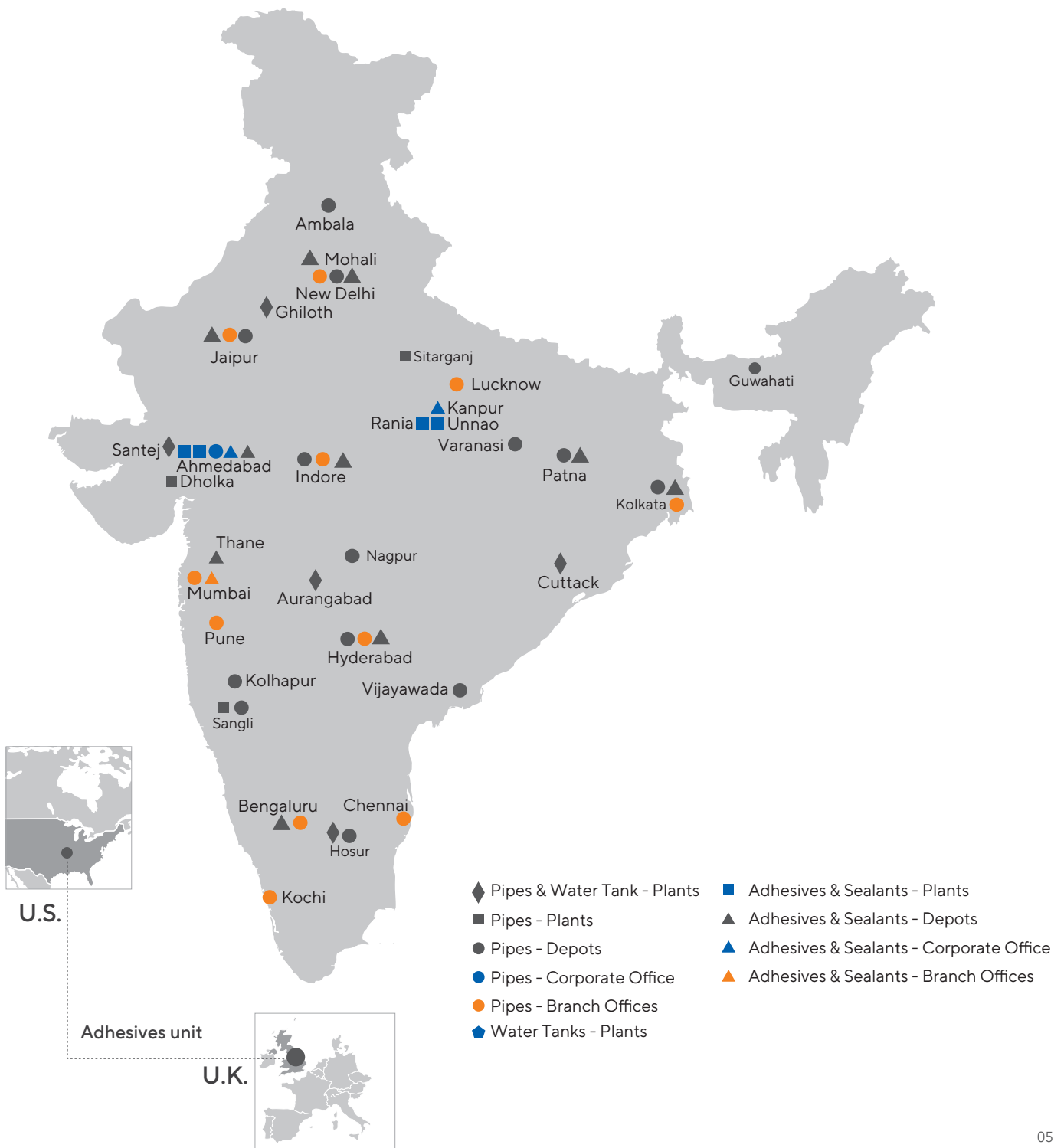

LEADING THE LEAD-FREE PIPE MOVEMENT

Lead (Pb on the Periodic Table) is one of the most naturally occurring elements on the planet. With little or no known biological benefit to humans, Lead causes a lot of damage and leads to poisoning when imbibed.

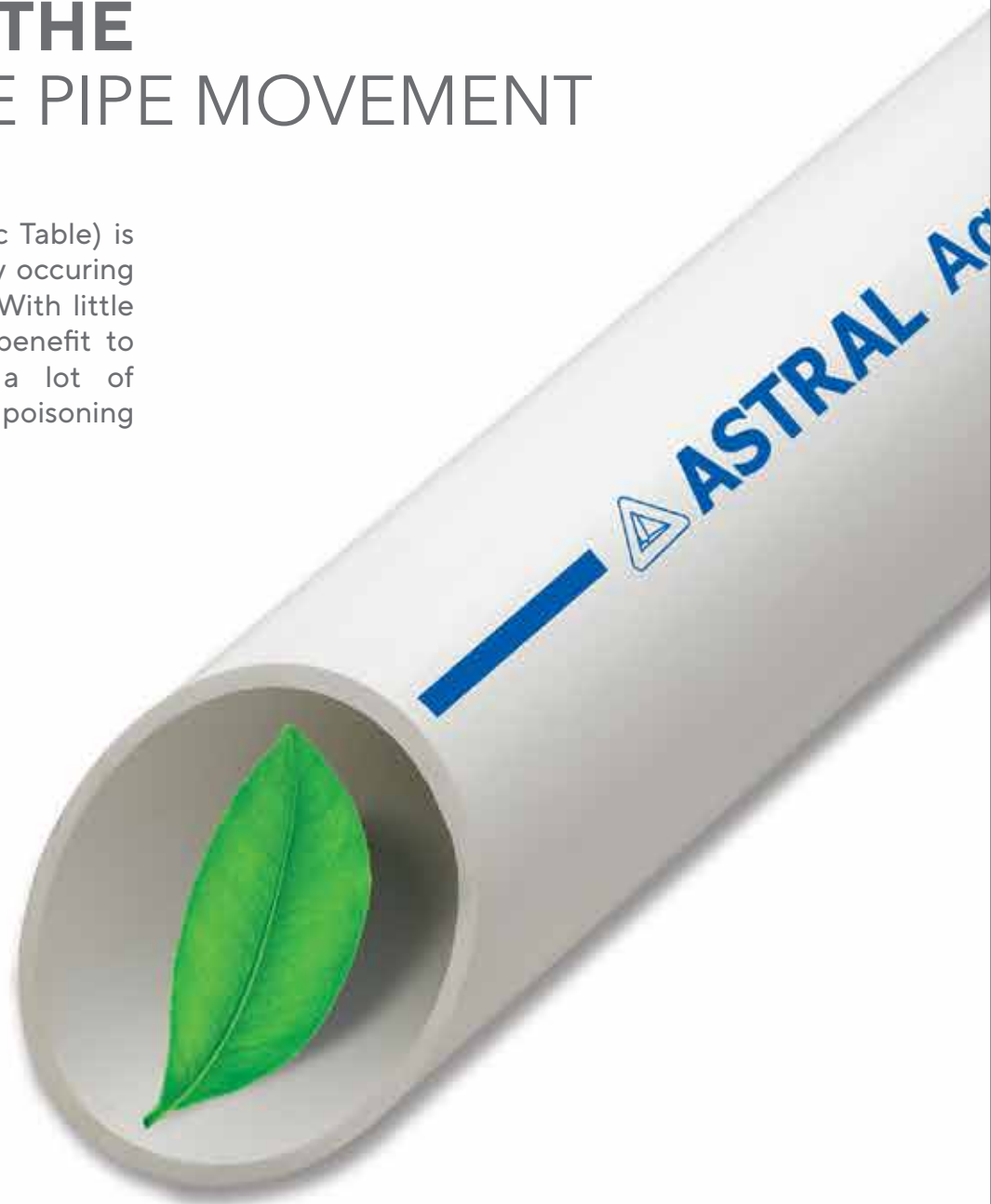

The lead can easily leach or dissolve into the water from transportation pipes and can be fatal. High blood lead levels in children can cause consequences which may be irreversible including learning disabilities, behavioural problems and mental retardation.



Aquarius® Lead Free UPVC

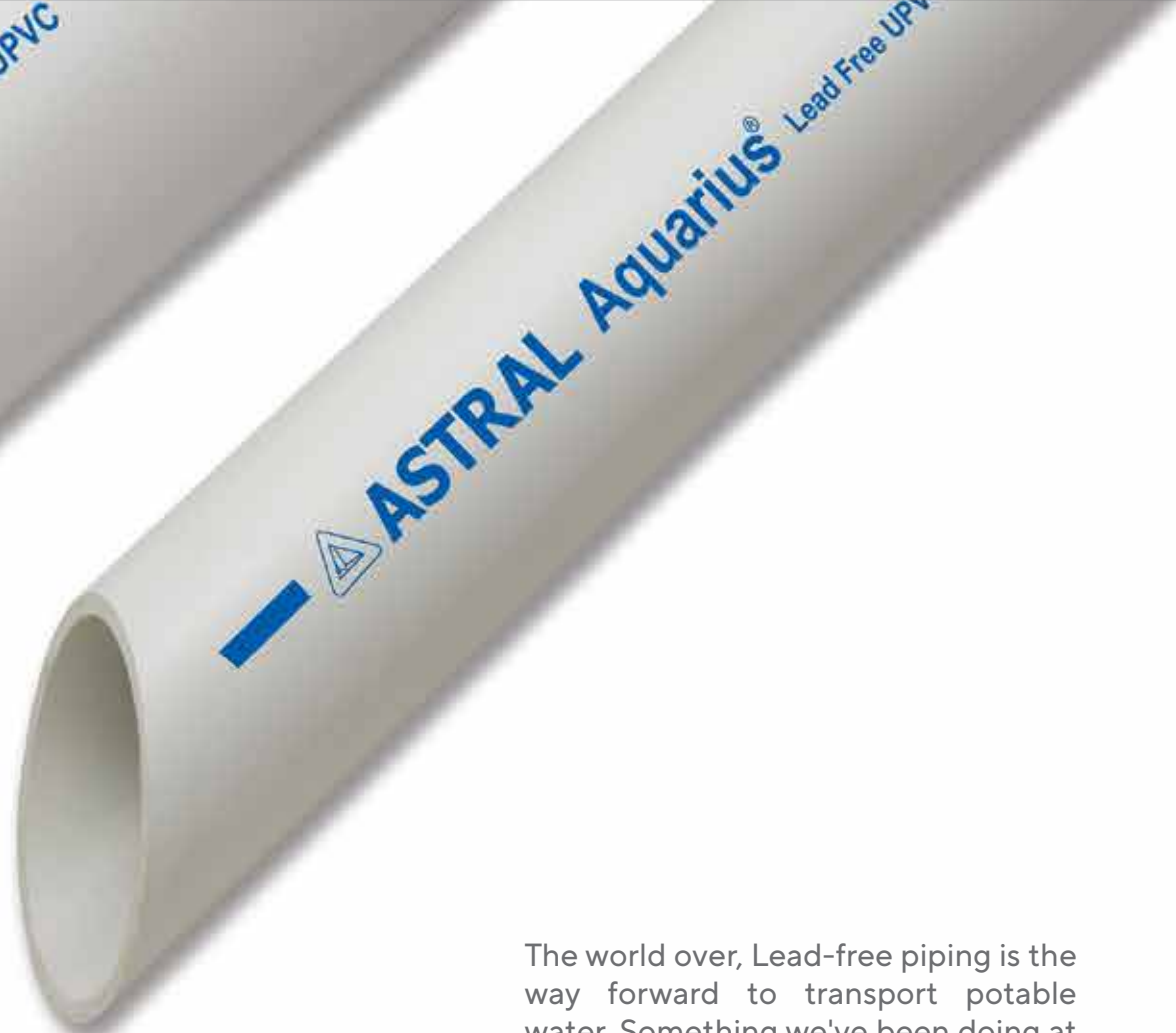

The world over, Lead-free piping is the way forward to transport potable water. Something we've been doing at Astral Pipes for over many years now. Our lead-free pipes have exceeded all quality benchmarks and continue to be one of our bestselling products.





ABOUT **ASTRAL** *Aquarius*[®]

ASTRAL Aquarius ASTM uPVC pipes and fittings are lead-free and hence non-toxic, easy to install and are made for life time trouble free service. ASTRAL Aquarius pipes and fittings are available in range of 15 mm (½") to 300 mm (12") with two different classes - SCH 40 and SCH 80. As the full line leading manufacturer of CPVC pipes and fittings for residential and industrial applications and now with ASTM uPVC pressure pipes and fittings, ASTRAL can be your one stop source for all the plastic piping system which you require for a lifetime plumbing solution.

THE DIFFERENCE BETWEEN uPVC & PVC

There has been a lot of confusion in the thermoplastics industry regarding the use of the terms uPVC and PVC when specifying thermoplastic piping products. For many years, certain regions of the world have preferred using the term uPVC when specifying unplasticized Polyvinyl Chloride piping products while other regions of the world, The United State of America for instance, prefer the acronym PVC (less the U) when specifying the same unplasticized PVC piping products. So uPVC and PVC both indicate same material - unplasticized or Rigid PVC. The most important aspect of specifying PVC piping products is not the abbreviation but the cell classification of the thermoplastic material. For rigid, unplasticized Type I Grade I PVC material with a hydrostatic design stress of 2000 psi the cell classification is 12454. These numbers indicate the minimum physical properties that a rigid, unplasticized thermoplastic compound must meet as per ASTM D1784 to be used in the manufacturing of pressure piping components. In summary, whether a thermoplastic vinyl piping, product is specified as uPVC is not important, it is the cell classification, and materials' physical properties that is most important.

PVC - POLYVINYL CHLORIDE

PVC is one of the specified thermoplastic for piping system components, including valves, fittings, flanges and many speciality products. PVC has excellent chemical and corrosion resistance to a broad range of fluids. ASTRAL uPVC materials conform to ASTM Cell Classification 12454-B of ASTM D1784 (formally designated as Type I, Grade I). The maximum recommended service temperature of PVC products is 60°C (140°F).

WHAT MAKES PVC IMPORTANT?

PVC makes a major contribution to the quality, safety and cost-effectiveness of construction materials, as well as helping to reduce the environmental impact of completed projects. PVC is the most widely used polymer in building and construction applications and over 50 percent of Western Europe's annual PVC production is used in this sector. PVC has a versatility that helps to meet modern and future design needs.

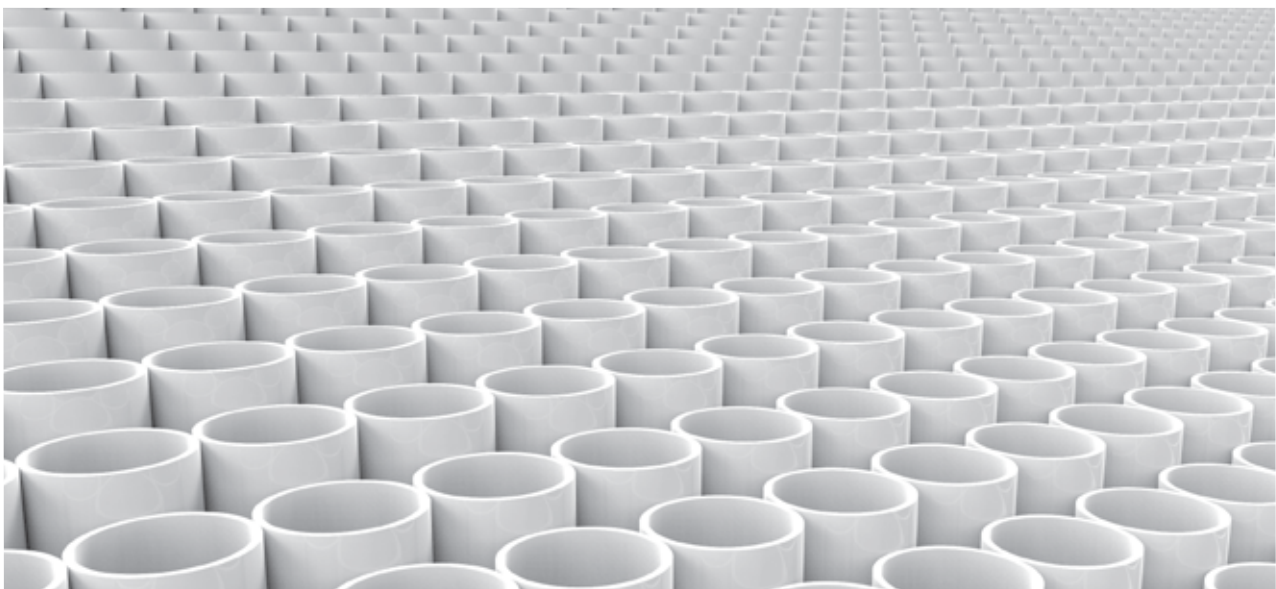

BENEFITS OF ASTRAL AQUARIUS SYSTEM OVER OTHER uPVC SYSTEMS

THREADED uPVC PIPE

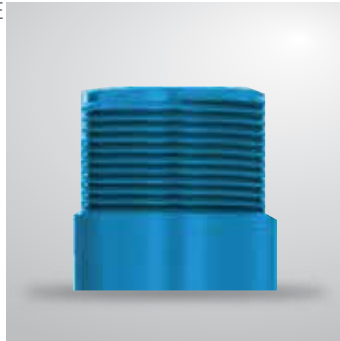

SOLVENT WELD uPVC PIPE

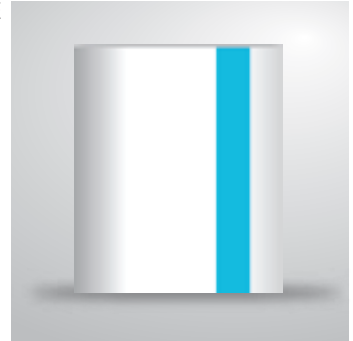

ASTRAL Aquarius uPVC pipes being lead free are non-toxic and hence favoured for use in applications such as potable water pipes. ASTRAL Aquarius uPVC plumbing system utilizes NSF (National Sanitation Foundation) approved one-step solvent cement, specifically formulated for the use. Joining is accomplished quickly and efficiently utilizing inexpensive tools thereby greatly reducing labour and installation cost. ASTRAL Aquarius uPVC pipes & fittings exhibit the well-known physical characteristics and other benefits of conventional uPVC piping such as good chemical and corrosion resistance, low thermal conductivity, high strength-to-weight ratio, good impact resistance and ease of installation.



ASTRAL AQUARIUS UPVC SOLVENT JOINT PLUMBING SYSTEM DOUBLES THE PRESSURE BEARING CAPACITY COMPARED TO THREADED uPVC PIPING SYSTEM.

STANDARDS & SPECIFICATIONS

- ASTM D 1784 - Rigid Poly Vinyl Chloride (PVC) Compounds
- ASTM D 1785 - Poly Vinyl Chloride (PVC) Plastic Pipes, SCH 40 & SCH 80
- ASTM D 2466 - Socket type Poly Vinyl Chloride (PVC) Plastic Pipe Fittings, SCH 40
- ASTM D 2467 - Socket type Poly Vinyl Chloride (PVC) Plastic Pipe Fittings, SCH 80
- ASTM D 2564 - Solvent Cements for Plastic Pipes & Fittings
- ASTM F 1498 - Taper Pipe threads 60° for Thermoplastics Pipe & Fittings
- ASTM D 2774 - Underground Installation of Thermoplastic Pipes
- ISO 7/1 - Pipe threads where pressure joints are made on threads - Part 1: Designation, Dimension & Tolerances

DESCRIPTIVE CODES

- ASTM** - American Society for Testing of Materials.
- BSP** - British Standard Pipe
- NPT** - National Pipe Threads (ANSI)
- MIPT** - Male Iron Pipe Threads
- SPIGOT** - Spigot End (IPS)
- MBSP** - Male BSP Threads
- PVC** - Poly Vinyl Chloride
- ANSI** - American National Standards Institute
- IPS** - Iron Pipe Size (ASTM)
- FIPT** - Female Iron Pipe Threads
- SOCKET** - Solvent Weld Socket
- FBSP** - Female BSP Threads
- NSF** - National Sanitation Foundation
- EPDM** - Ethylene Propylene Rubber



IMPORTANT FOR INSTALLERS & USERS

WATER HAMMER

ASTRAL recommends that all uPVC plastic piping systems be designed and constructed to avoid excessive WATER HAMMER. Water hammer can cause damage and failure to pipe, valves and fittings within the piping system

THREADED CONNECTIONS

Use a quality grade thread sealant. Do not use substances that could cause stress cracking to plastic. Major attention must be given while making plastic thread joints. 1 to 2 turns beyond FINGER TIGHT is generally all that is required to make a sound plastic connection. Unnecessary OVER TIGHTENING will cause DAMAGE TO BOTH PIPES & FITTINGS. Also give proper attention while selecting the threaded fittings, as ASTRAL manufacture some fittings with NPT threads & some fittings with BSP threads to give more versatility to customer NPT threads which are not compatible with BSP threads.

SEAL & GASKET LUBRICANTS

Some lubricants, including vegetable oils are known to cause stress cracking in thermoplastic materials. A mild soap or commercially available pipe gasket lubricant suitable for uPVC is recommended where lubrication is required for installation or maintenance service (especially with Flange joints). Choice of lubricant is at the discretion of the installer.

FLOW VELOCITIES

System should not be operated or flushed out at flow velocities greater than 5 feet per second.

The following information is provided as a guide only. Actual allowable working pressure may vary widely according to conditions. Additionally, pressure de-rating at elevated temperatures must be taken into account. Certain fitting configurations may have other assigned pressure limitations (i.e., Wyes, Unions, Flanges, Valves etc). Contact Astral Technical Services for additional information.

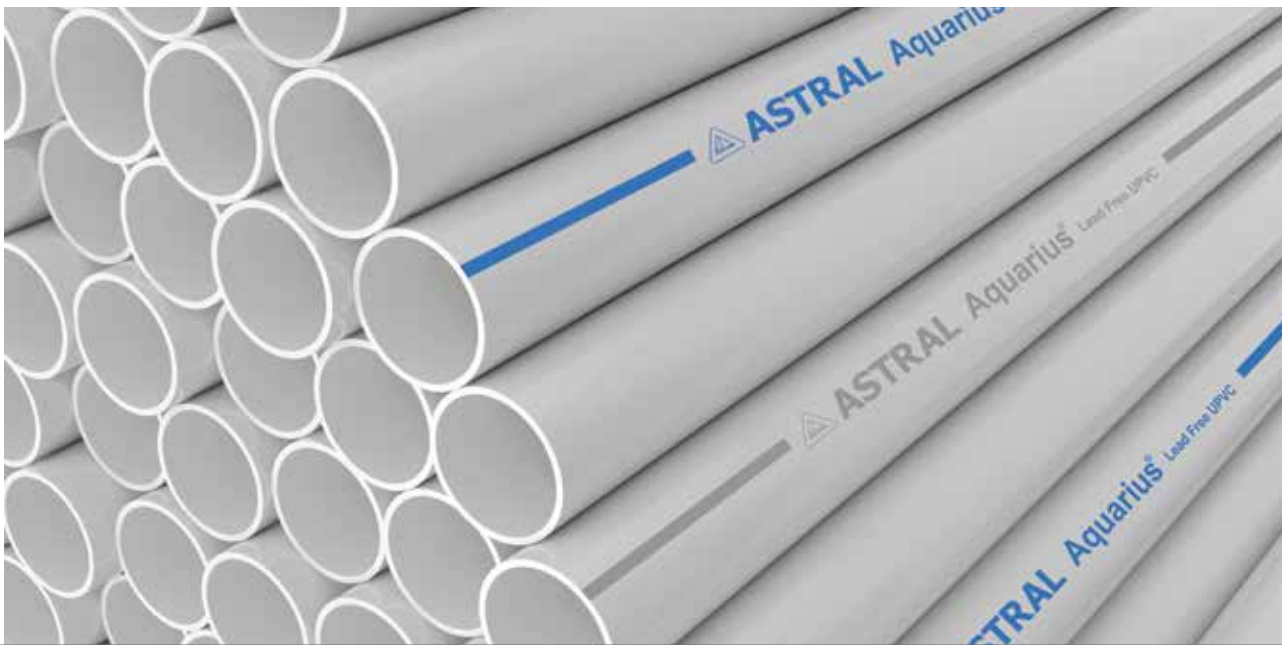

KEY PROPERTIES



STRONG AND LIGHT WEIGHT

ASTRAL Aquarius lead-free plumbing system is tough, durable with high tensile and impact strength. The system is light weight and can be transported easily from one place to another.



DURABLE

ASTRAL Aquarius lead-free plumbing system is durable and free from weaknesses caused by rusting, weathering and chemical action and hence imparts service life of more than 50 years.



FIRE RESISTANT

ASTRAL Aquarius lead-free plumbing system is inherently difficult to ignite and stops burning once the source of heat is removed. Compared to its common plastic alternatives, uPVC performs better in terms of lower combustibility, flammability, flame propagation and heat release. Newly developed advantages in terms of lower acid emissions, smoke generation and enhanced fire resistance.



UV STABILIZED

ASTRAL Aquarius lead-free plumbing system can be used in sunlight exposed conditions. However, ASTRAL recommends a standard grade of exterior latex paint (water base) which will protect the system adequately.



EASY TO INSTALL

ASTRAL Aquarius lead-free pipes can be cut, shaped, welded and joined easily.



SAFE MATERIAL FOR DRINKING WATER

ASTRAL Aquarius pipes are non-toxic and lead-free which makes them a safe material for potable water. It is also the world's most researched and thoroughly tested material for uPVC which meets all international standards for safety and health for both the products and applications.



MAXIMUM FLOW RATE

Smooth inner surface ensures high flow rate and low frictional losses. The system is leach and scale free.



CHEMICAL RESISTANCE

uPVC is generally inert to most mineral acids, alkalies, salts and paraffinic hydrocarbon solutions. For more information on uPVC chemical resistance refer to Chemical Resistance of Rigid Vinyls Based.



GOOD INSULATOR

ASTRAL Aquarius pipes are non-conductor of electricity. So it makes the plumbing system safe when working with electrical tools or equipment.



WIDE RANGE

ASTRAL Aquarius lead-free plumbing system is available from ½" (15 mm) to 12" (300 mm) with wide range of fittings, transition fittings, valves and specially designed brass inserted fittings to suit any design criteria.

FIELDS OF APPLICATION

- Cold Water Plumbing Application
- Water Distribution Mains
- Industrial Process Lines
- Swimming Pools
- Plants & Tanning Plants
- Hand Pumps
- Sugar, Paper & Distillery Industries
- Salt Water Line
- Aggressive Corrosive Fluid Transportation
- Coal Washing & Ash Handling
- Down Take Lines

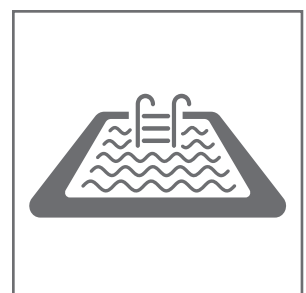
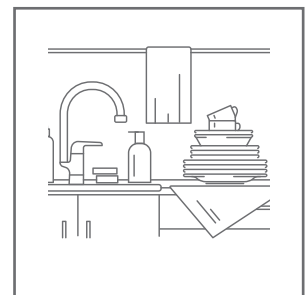

PRESSURE PIPES AND FITTINGS

PRESSURE RATING @23°C uPVC SCHEDULE 40

Nominal Size			Average Outside Diameter		Minimum Wall Thickness		Maximum Work Pressure at 73°F (PSI)	Maximum Work Pressure at 23°C (kg/cm ²)
(cm)	(mm)	(in.)	(in.)	(mm)	(in.)	(mm)		
1.5	15	½	0.840	21.34	0.109	2.77	600	42.19
2.0	20	¾	1.050	26.67	0.113	2.87	480	33.75
2.5	25	1	1.315	33.40	0.133	3.38	450	31.64
3.2	32	1¼	1.660	42.16	0.140	3.56	370	26.01
4.0	40	1½	1.900	48.26	0.145	3.68	330	23.20
5.0	50	2	2.375	60.32	0.154	3.91	280	19.69
6.5	65	2½	2.875	73.02	0.203	5.16	300	21.09
8.0	80	3	3.500	88.90	0.216	5.49	260	18.28
10.0	100	4	4.500	114.30	0.237	6.02	220	15.47
15.0	150	6	6.625	168.28	0.280	7.11	180	12.66
20.0	200	8	8.625	219.08	0.322	8.18	160	11.25
25.0	250	10	10.750	273.05	0.365	9.27	140	9.84
30.0	300	12	12.750	323.85	0.406	10.31	130	9.14

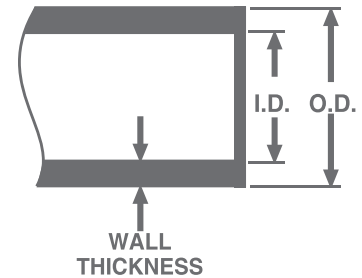

MPa = Mega Pascal 1 MPa = 10 kg / cm² 1 kg / cm² = 14.223343 PSI.

PRESSURE RATING @23°C uPVC SCHEDULE 80

Nominal Size			Average Outside Diameter		Minimum Wall Thickness		Maximum Work Pressure at 73°F (PSI)	Maximum Work Pressure at 23°C (kg/cm ²)
(cm)	(mm)	(in.)	(in.)	(mm)	(in.)	(mm)		
1.5	15	½	0.840	21.34	0.147	3.73	850	59.76
2.0	20	¾	1.050	26.67	0.154	3.91	690	48.51
2.5	25	1	1.315	33.40	0.179	4.55	630	44.29
3.2	32	1¼	1.660	42.16	0.191	4.85	520	36.56
4.0	40	1½	1.900	48.26	0.200	5.08	470	33.04
5.0	50	2	2.375	60.32	0.218	5.54	400	28.12
6.5	65	2½	2.875	73.02	0.276	7.01	420	29.53
8.0	80	3	3.500	88.90	0.300	7.62	370	26.01
10.0	100	4	4.500	114.30	0.337	8.56	320	22.50
15.0	150	6	6.625	168.28	0.432	10.97	280	19.69
20.0	200	8	8.625	219.08	0.500	12.70	250	17.57
25.0	250	10	10.750	273.05	0.593	15.06	230	16.17
30.0	300	12	12.750	323.85	0.687	17.45	230	16.17

MPa = Mega Pascal 1 MPa = 10 kg / cm² 1 kg / cm² = 14.223343 PSI.

TEMPERATURE PRESSURE DE-RATING FACTOR

The operating pressure of uPVC pipe will be reduced as the operating temperature increases above 23°C (73°F). To calculate this reduction, multiply the operating pressure with the correction factors shown below at a operating temperature of system :

Operating Temp.°C (°F)	23 (73)	27 (80)	32 (90)	38 (100)	43 (110)	49 (120)	54 (130)	60 (140)
uPVC	100%	90%	75%	62%	50%	40%	30%	22%

NOTES : (1) Valves, Unions and Specialty Products have different elevated temperature ratings than pipes. (2) Threaded valves should not be used at temperature above 110°F (43° C) for PVC (3) Flanged joints have a base pressure rating of 150 PSI at 23° C

PVC SCHEDULE 40 AND SCHEDULE 80 FITTINGS

The following information is provided as a guide only. Actual allowable working pressure may vary widely according to conditions. Additionally, pressure de-rating at elevated temperatures must be taken into account. Certain fitting configurations may have other assigned pressure limitations (i.e. Unions, Flanges, Valves etc). Contact Astral Technical Services for additional information.

PRESSURE RATING @23°C uPVC SCHEDULE 40 & SCHEDULE 80

Maximum Work Pressure at 23°C (kg/cm ²)						
Schedule 40				Schedule 80		
Nominal Size (in.)	Pipe	Solvent Cemented Joint	Threaded Joint	Pipe	Solvent Cemented Joint	Threaded Joint
½	42.19	25.31	21.09	59.76	35.85	29.88
¾	33.75	20.24	16.87	48.51	29.10	24.25
1	31.64	18.98	15.81	44.29	26.57	22.14
1¼	26.01	15.60	13.00	36.56	21.93	18.27
1½	23.20	13.92	11.60	33.04	19.82	16.52
2	19.69	11.81	9.84	28.12	16.87	14.06
2½	21.09	12.65	10.54	29.53	17.71	14.76
3	18.28	10.96	9.13	26.01	15.60	13.00
4	15.47	9.28	7.73	22.50	13.49	11.24
6	12.66	7.59	6.32	19.69	11.81	9.84
8	11.25	6.74	5.62	17.57	10.54	8.78
10	9.84	5.90	4.92	16.17	9.70	8.08
12	9.14	5.48	4.56	16.17	9.70	8.08

NOTES : (1) Water pressure Ratings At 73°F (23°C) for Schedule 40 and Schedule 80 Plastic Pipe, ASTM D 1785 for PVC.

(2) Threading of Schedule 40 plastic pipe is not permitted. Recommended pressures apply to molded fittings only.

(Not For Use With Compressed Air , Gas or Vacuum)

PHYSICAL PROPERTIES OF PVC MATERIALS

PROPERTY	UNITS	PVC	ASTM NO.
Specific Gravity	g/cc	1.41 - 1.46	D 792
Tensile Strength (73°F)	PSI	7,200	D 638
Modulus of Elasticity in Tension (73°F)	PSI	4,60,000	D 638
Flexural Strength (73°F)	PSI	13,200	D 790
Izod Impact (notched at 73°F)	ft lb/in.	0.65	D 256
Hardness (Durometer D)	----	80 ± 3	D 2240
Hardness (Rockwell R)	----	110 - 120	D 785
Compressive Strength (73°F)	PSI	9,000	D 695
Hydrostatic Design Stress	PSI	2,000	D 1598
Coefficient of Linear Expansion	in./in./°F	3.1 x 10 ⁻⁵	D 696
Heat Deflection Temperature at 66 psi	°F	165	D 648
Coefficient of Thermal Conductivity	BTU/hr/sq. ft/°F/in.	1.2	C 177
Specific Heat	BTU/F/lb	0.25	D 2766
Limiting Oxygen Index	%	43	D 2863
Water Absorption (24 hrs at 73°F)	% weight gain	0.05	D 570
Cell Classification-Pipe	----	12454-B	D 1784
Cell Classification-Fittings	----	12454-B	D 1784

Above data is based upon information provided by the raw material manufacturers. It should be used only as a recommendation and not as a guarantee of performance.

BASIC SOCKET DIMENSIONS

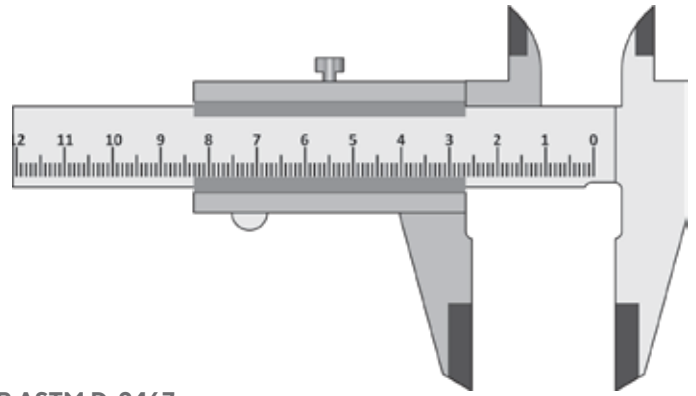

SCHEDULE 40 AS PER ASTM D-2466, SCHEDULE 80 AS PER ASTM D-2467

Nominal Size		Diameter (in.)			Socket Length Minimum C (in.)	
		Entrance A	Bottom B	Tolerance	SCH 40	SCH 80
(in.)	(mm)					
½	15	0.848	0.836	±0.004	0.688	0.875
¾	20	1.058	1.046	±0.004	0.719	1.000
1	25	1.325	1.310	±0.005	0.875	1.125
1¼	32	1.670	1.655	±0.005	0.938	1.250
1½	40	1.912	1.894	±0.006	1.094	1.375
2	50	2.387	2.369	±0.006	1.156	1.500
2½	65	2.889	2.868	±0.007	1.750	1.750
3	80	3.516	3.492	±0.008	1.875	1.875
4	100	4.518	4.491	±0.009	2.000	2.250
6	150	6.647	6.614	±0.011	3.000	3.000
8	200	8.655	8.610	±0.015	4.000	4.000
10	250	10.780	10.735	±0.015	5.000	5.000
12	300	12.780	12.735	±0.015	6.000	6.000

**AMERICAN NATIONAL STANDARD TAPER PIPE THREADS (NPT)
ANSI STANDARD B1.20.1 ASTM STANDARD F 1498**

Nominal Size		Threads per inch	Effective Thread Length L (in.)	Pitch of Thread P (in.)
(in.)	(mm)			
½	15	14	0.5337	0.07143
¾	20	14	0.5457	0.07143
1	25	11½	0.6828	0.08696
1¼	32	11½	0.7068	0.08696
1½	40	11½	0.7235	0.08696
2	50	11½	0.7565	0.08696
2½	65	8	1.1375	0.12500
3	80	8	1.2000	0.12500
4	100	8	1.3000	0.12500

BSP ISO 7/1 PARELLEL THREADS

Nominal Size		Threads per inch	Effective Thread Length L (in.)	Pitch of Thread P (in.)
(in.)	(mm)			
½	15	14	13.152	1.8143
¾	20	14	14.514	1.8143
1	25	11	16.714	2.3091
1¼	32	11	19.050	2.3091
1½	40	11	19.050	2.3091
2	50	11	23.378	2.3091
2½	65	11	26.698	2.3091
3	80	11	29.873	2.3091
4	100	11	35.791	2.3091

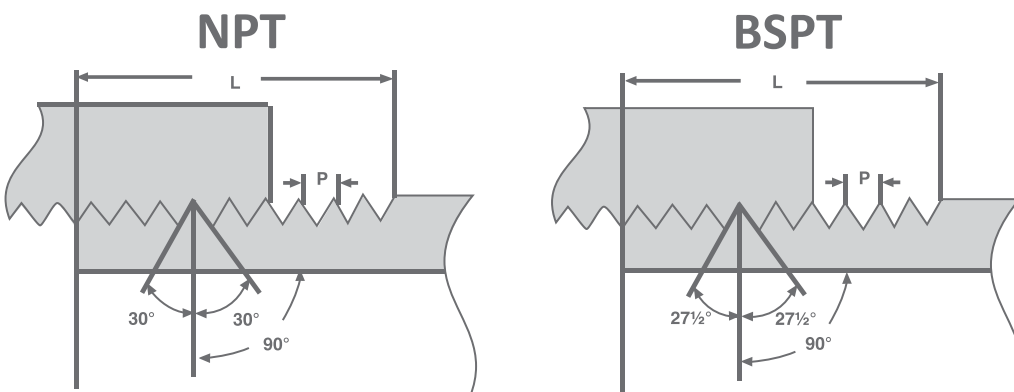

PRODUCT



ASTRAL
Aquarius[®]

RANGE

uPVC PRESSURE PIPES AS PER ASTM D-1785

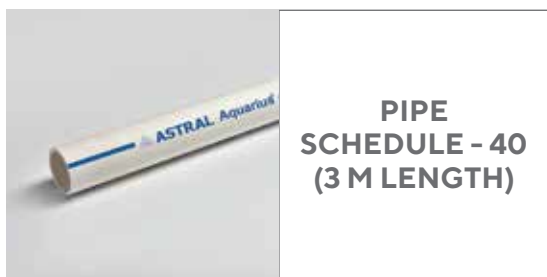

Size (cm)	Size (inch)	Product Code	Std. Pkg. (Nos.)
1.5	½	M051400301	50
2.0	¾	M051400302	30
2.5	1	M051400303	20
3.2	1¼	M051400304	15
4.0	1½	M051400305	10
5.0	2	M051400306	08
6.5	2½	M051400307	05
8.0	3	M051400308	03
10.0	4	M051400309	02
15.0	6	M051400310	01
20.0	8	M051400311	01
25.0	10	M051400312	01
30.0	12	M051400313	01



Size (cm)	Size (inch)	Product Code	Std. Pkg. (Nos.)
1.5	½	M051400601	30
2.0	¾	M051400602	20
2.5	1	M051400603	15
3.2	1¼	M051400604	10
4.0	1½	M051400605	10
5.0	2	M051400606	06
6.5	2½	M051400607	05
8.0	3	M051400608	03
10.0	4	M051400609	02
15.0	6	M051400610	01
20.0	8	M051400611	01
25.0	10	M051400612	01
30.0	12	M051400613	01

uPVC PRESSURE FITTINGS SCHEDULE 40 AS PER ASTM D-2466

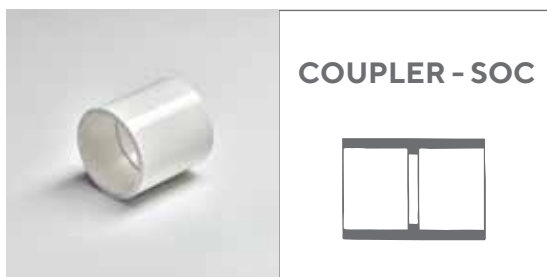

Size (cm)	Size (inch)	Product Code	Pkg.(Nos.) Std. Mast.
1.5	½	M052401001	100 1400
2.0	¾	M052401002	50 300
2.5	1	M052401003	25 350
3.2	1¼	M052401004	10 200
4.0	1½	M052401005	10 150
5.0	2	M052401006	10 110
6.5	2½	M052401007	05 50
8.0	3	M052401008	05 35
10.0	4	M052401009	- 24
15.0	6	M052401010	- 02



Size (cm)	Size (inch)	Product Code	Pkg.(Nos.) Std. Mast.
1.5	½	M052400501	100 1000
2.0	¾	M052400502	50 500
2.5	1	M052400503	25 250
3.2	1¼	M052400504	10 150
4.0	1½	M052400505	10 110
5.0	2	M052400506	5 65
6.5	2½	M052400507	5 35
8.0	3	M052400508	0 25
10.0	4	M052400509	0 14
15.0	6	M052400510	0 03

uPVC PRESSURE FITTINGS

SCHEDULE 40 AS PER ASTM D-2466



Size (cm)	Size (inch)	Product Code	Pkg.(Nos.) Std. Mast.	
1.5	½	M052400801	90	450
2.0	¾	M052400802	50	250
2.5	1	M052400803	25	125
3.2	1¼	M052400804	10	50
4.0	1½	M052400805	10	60
5.0	2	M052400806	5	30



Size (cm)	Size (inch)	Product Code	Pkg.(Nos.) Std. Mast.	
1.5	½	M052400101	50	550
2.0	¾	M052400102	25	300
2.5	1	M052400103	25	175
3.2	1¼	M052400104	10	100
4.0	1½	M052400105	10	70
5.0	2	M052400106	5	40
6.5	2½	M052400107	-	27
8.0	3	M052400108	-	18
10.0	4	M052400109	-	10
15.0	6	M052400110	-	02



Size (cm)	Size (inch)	Product Code	Pkg.(Nos.) Std. Mast.	
1.5	½	M052402301	100	500
2.0	¾	M052402302	50	300
2.5	1	M052402303	25	325
3.2	1¼	M052402304	10	100
4.0	1½	M052402305	15	75
5.0	2	M052402306	10	40



Size (cm)	Size (inch)	Product Code	Pkg.(Nos.) Std. Mast.	
1.5	½	M052400401	50	300
2.0	¾	M052400402	25	150
2.5	1	M052400403	25	75
3.2	1¼	M052400404	10	50
4.0	1½	M052400405	10	40
5.0	2	M052400406	05	20

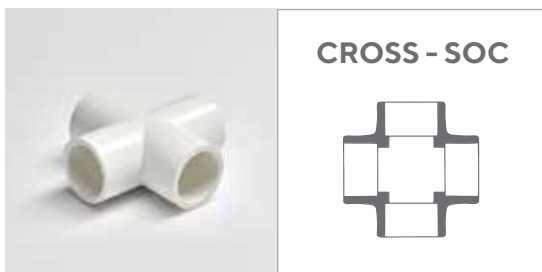

Size (cm)	Size (inch)	Product Code	Pkg.(Nos.) Std. Mast.	
1.5	½	M052402401	50	200
2.0	¾	M052402402	25	100
1.0	1	M052402403	25	75



Size (cm)	Size (inch)	Product Code	Pkg.(Nos.) Std. Mast.	
2.0x1.5	¾x½	M052401614	50	700

uPVC PRESSURE FITTINGS

SCHEDULE 40 AS PER ASTM D-2466

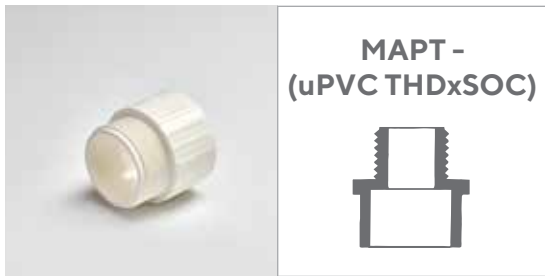

Size (cm)	Size (inch)	Product Code	Pkg.(Nos.) Std. Mast.
1.5	½	M052401301	100 1700
2.0	¾	M052401302	50 500
2.5	1	M052401303	50 500
3.2	1¼	M052401304	20 480
4.0	1½	M052401305	16 320
5.0	2	M052401306	12 192



Size (cm)	Size (inch)	Product Code	Pkg.(Nos.) Std. Mast.
1.5	½	M052401601	100 1300
2.0	¾	M052401602	50 400
2.5	1	M052401603	25 400
3.2	1¼	M052401604	10 130
4.0	1½	M052401605	10 100
5.0	2	M052401606	10 70



Size (cm)	Size (inch)	Product Code	Pkg.(Nos.) Std. Mast.
1.5	½	M052402501	10 80
2.0	¾	M052402502	10 60
2.5	1	M052402503	10 40
3.2	1¼	M052402504	10 30
4.0	1½	M052402505	10 20
5.0	2	M052402506	05 15



Size (cm)	Size (inch)	Product Code	Pkg.(Nos.) Std. Mast.
1.5	½	M052404101	100 1200
2.0	¾	M052404102	100 600
2.5	1	M052404103	50 350
3.2	1¼	M052404104	10 220
4.0	1½	M052404105	10 270
5.0	2	M052404106	10 90
6.5	2½	M052404107	05 50
8.0	3	M052404108	05 35
10.0	4	M052404109	- 22



Size (cm)	Size (inch)	Product Code	Pkg.(Nos.) Std. Mast.
2.0 x 1.5	¾ x ½	M052401114	100 400
2.5 x 1.5	1 x ½	M052401115	50 550
2.5 x 2.0	1 x ¾	M052401116	50 200
3.2 x 1.5	1¼ x ½	M052401117	25 200
3.2 x 2.0	1¼ x ¾	M052401118	25 200
3.2 x 2.5	1¼ x 1	M052401119	25 175
4.0 x 1.5	1½ x ½	M052401120	25 150
4.0 x 2.0	1½ x ¾	M052401121	25 150
4.0 x 2.5	1½ x 1	M052401122	25 150
4.0 x 3.2	1½ x 1¼	M052401123	10 150
5.0 x 1.5	2 x ½	M052401124	25 100
5.0 x 2.0	2 x ¾	M052401125	25 100
5.0 x 2.5	2 x 1	M052401126	30 120
5.0 x 3.2	2 x 1¼	M052401127	10 40
5.0 x 4.0	2 x 1½	M052401128	10 50

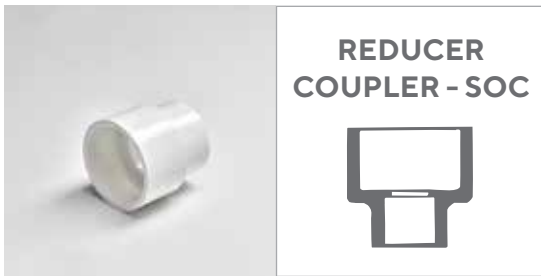

**REDUCER
COUPLER - SOC**



Size (cm)	Size (inch)	Product Code	Pkg.(Nos.) Std. Mast.	
6.5 x 2.5	2½ X 1	M052401131	40	40
6.5 x 3.2	2½ X 1¼	M052401132	40	40
6.5 x 4.0	2½X 1½	M052401133	40	40
6.5 x 5.0	2½ X 2	M052401134	40	40
8.0 x 2.5	3 x 1	M052401137	42	42
8.0 x 3.2	3 X 1¼	M052401138	42	42
8.0 x 4.0	3 X 1½	M052401139	42	42
8.0 x 5.0	3 X 2	M052401140	42	42
8.0 x 6.5	3 X 2½	M052401141	42	42
10.0x4.0	4 X 1½	M052401146	24	24
10.0x5.0	4 X 2	M052401147	24	24
10.0x6.5	4 X 2½	M052401148	24	24
10.0x8.0	4 X 3	M052401149	24	24



**LONG RADIUS
BEND 90° -
SOC**

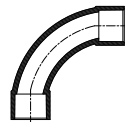

Size (cm)	Size (inch)	Product Code	Pkg.(Nos.) Std. Mast.	
1.5	½	F052400901	-	120
2.0	¾	F052400902	-	85
2.5	1	F052400903	-	50
3.2	1¼	F052400904	-	30
4.0	1½	F052400905	-	18
5.0	2	F052400906	-	12
6.5	2½	F052400907	-	06
8.0	3	F052400908	-	05
10.0	4	F052400909	-	04
15.0	6	F052400910	-	01

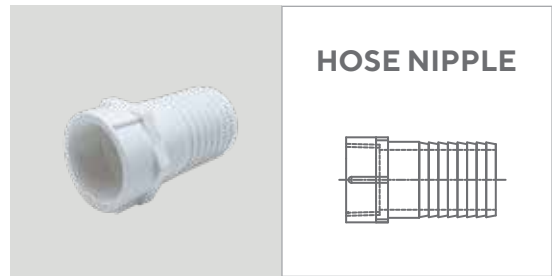

HOSE NIPPLE

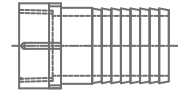

Size (cm)	Size (inch)	Product Code	Pkg.(Nos.) Std. Mast.	
5.0	2	M0524015005	10	50
6.3	2½	M0524015006	05	40

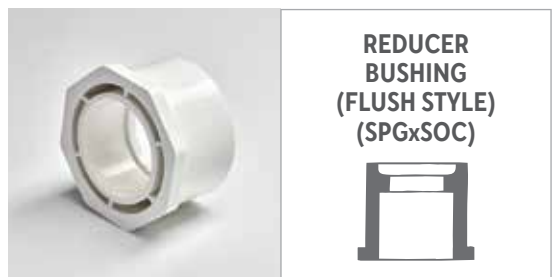

**REDUCER
BUSHING
(FLUSH STYLE)
(SPGxSOC)**



Size (cm)	Size (inch)	Product Code	Pkg.(Nos.) Std. Mast.	
2.0 x 1.5	¾ x ½	M052401914	100	900
2.5 x 1.5	1 x ½	M052401915	50	450
2.5 x 2.0	1 x ¾	M052401916	50	450
3.2 x 1.5	1¼ x ½	M052401917	25	300
3.2 x 2.0	1¼ x ¾	M052401918	25	300
3.2 x 2.5	1¼ x 1	M052401919	25	500
4.0 x 1.5	1½ x ½	M052401920	25	350
4.0 x 2.0	1½ x ¾	M052401921	25	200
4.0 x 2.5	1½ x 1	M052401922	25	350
4.0 x 3.2	1½ x 1¼	M052401923	25	400
5.0 x 1.5	2 x ½	M052401924	10	120
5.0 x 2.0	2 x ¾	M052401925	10	120
5.0 x 2.5	2 x 1	M052401926	10	100
5.0 x 3.2	2 x 1¼	M052401927	10	120
5.0 x 4.0	2 x 1½	M052401928	10	120
6.5 x 3.2	2½ x 1¼	M052401932	05	25
6.5 x 4.0	2½ x 1½	M052401933	05	50
6.5 x 5.0	2½ x 2	M052401934	05	60
8.0 x 4.0	3 x 1½	M052401939	05	35
8.0 x 5.0	3 x 2	M052401940	05	35
8.0 x 6.5	3 x 2½	M052401941	05	35
10.0 x 5.0	4 x 2	M052401947	05	20
10.0 x 6.5	4 x 2½	M052401948	05	10
10.0 x 8.0	4 x 3	M052401949	05	20

uPVC PRESSURE FITTINGS

SCHEDULE 40 AS PER ASTM D-2466



Size (cm)	Size (inch)	Product Code	Pkg.(Nos.) Std. Mast.	
1.5	½	M052402701LH	1	120
2.0	¾	M052402702LH	1	-
2.5	1	M052402703LH	1	50
3.2	1¼	M052402704LH	1	40
4.0	1½	M052402705LH	1	30
5.0	2	M052402706LH	1	15



Size (cm)	Size (inch)	Product Code	Pkg.(Nos.) Std. Mast.	
2.0 x 1.5	¾ x ½	M052400214	25	350
2.5 x 1.5	1 x ½	M052400215	25	200
2.5 x 2.0	1 x ¾	M052400216	25	175
3.2 x 1.5	1¼ x ½	M052400217	10	120
3.2 x 2.0	1¼ x ¾	M052400218	10	120
3.2 x 2.5	1¼ x 1	M052400219	10	120
4.0 x 1.5	1½ x ½	M052400220	10	90
4.0 x 2.0	1½ x ¾	M052400221	10	40
4.0 x 2.5	1½ x 1	M052400222	10	80
4.0 x 3.2	1½ x 1¼	M052400223	10	70
5.0 x 1.5	2 x ½	M052400224	05	60
5.0 x 2.0	2 x ¾	M052400225	05	60
5.0 x 2.5	2 x 1	M052400226	05	60
5.0 x 3.2	2 x 1¼	M052400227	05	50
5.0 x 4.0	2 x 1½	M052400228	05	50
6.5 x 2.5	2½ X 1	M052400231	20	20
6.5 x 3.2	2½ X 1¼	M052400232	18	18
6.5 x 4.0	2½ X 1½	M052400233	18	18
6.5 x 5.0	2½ X 2	M052400234	17	17
8.0x2.5	3x1	M052400237	12	12
8.0x3.2	3x1¼	M052400238	12	12
8.0x4.0	3x1½	M052400239	12	12
8.0x5.0	3x2	M052400240	10	10
8.0x6.5	3x2½	M052400241	10	10
10.0x4.0	4 X 1½	M052400246	06	06
10.0 x 5.0	4 X 2	M052400247	06	06
10.0 x 6.5	4 X 2½	M052400248	05	05
10.0 x 8.0	4x3	M052400249	06	06

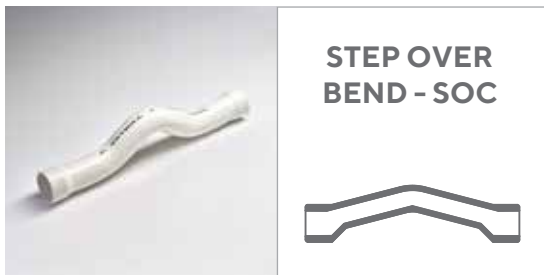

Size (cm)	Size (inch)	Product Code	Pkg.(Nos.) Std. Mast.	
1.5	½	F052402801	-	90
2.0	¾	F052402802	-	60
2.5	1	F052402803	-	30
3.2	1¼	F052402804	-	25
4.0	1½	F052402805	-	20
5.0	2	F052402806	-	10



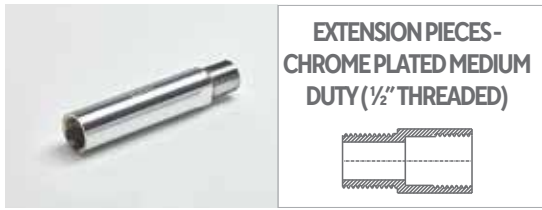

Size (cm)	Size (inch)	Product Code	Pkg.(Nos.) Std. Mast.
2.5	1	T143-010MØ	- 96
4.0	1½	T143-015MØ	- 64
5.0	2	T143-020MØ	- 48
6.5	2½	T143-025MØ	- 40
8.0	3	T143-030MØ	- 32
10.0	4	T143-040MØ	- 24
12.5	5	T143-050MØ	- 20
15.0	6	T143-060MØ	- 16



Size (cm)	Size (inch)	Product Code	Pkg.(Nos.) Std. Mast.
2.5	1	T143-010HØ	- 96
4.0	1½	T143-015HØ	- 64
5.0	2	T143-020HØ	- 48
6.5	2½	T143-025HØ	- 40
8.0	3	T143-030HØ	- 32
10.0	4	T143-040HØ	- 24
12.5	5	T143-050HØ	- 20
15.0	6	T143-060HØ	- 16

uPVC PRESSURE PIPES SCHEDULE 80 AS PER ASTM D-1785

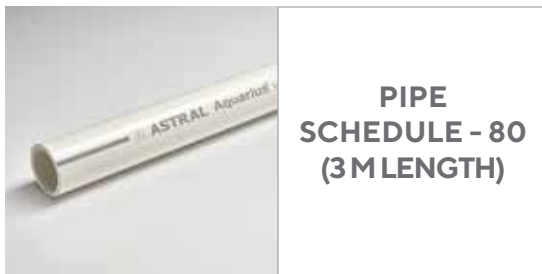

Size (cm)	Size (inch)	Product Code	Std. Pkg. (Nos.)
1.5	½	M051800301	50
2.0	¾	M051800302	30
2.5	1	M051800303	20
3.2	1¼	M051800304	15
4.0	1½	M051800305	10
5.0	2	M051800306	08
6.5	2½	M051800307	05
8.0	3	M051800308	03
10.0	4	M051800309	02
15.0	6	M051800310	01
20.0	8	M051800311	01
25.0	10	M051800312	01
30.0	12	M051800313	01



Size (cm)	Size (inch)	Product Code	Std. Pkg. (Nos.)
1.5	½	M051800601	30
2.0	¾	M051800602	20
2.5	1	M051800603	15
3.2	1¼	M051800604	10
4.0	1½	M051800605	10
5.0	2	M051800606	06
6.5	2½	M051800607	05
8.0	3	M051800608	03
10.0	4	M051800609	02
15.0	6	M051800610	01
20.0	8	M051800611	01
25.0	10	M051800612	01
30.0	12	M051800613	01

uPVC PRESSURE FITTINGS

SCHEDULE 80 AS PER ASTM D-2467

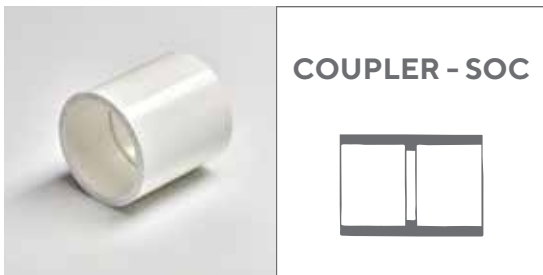

Size (cm)	Size (inch)	Product Code	Pkg.(Nos.) Std. Mast.	
1.5	½	M052801001	100	400
2.0	¾	M052801002	50	300
2.5	1	M052801003	25	150
3.2	1¼	M052801004	10	80
4.0	1½	M052801005	10	70
5.0	2	M052801006	10	50
6.5	2½	M052801007	05	20
8.0	3	M052801008	05	15
10.0	4	M052801009	-	12
15.0	6	M052801010	-	02
20.0	8	M052801011	-	01
25.0	10	M052801012	-	01
30.0	12	M052801013	-	01



Size (cm)	Size (inch)	Product Code	Pkg.(Nos.) Std. Mast.	
1.5	½	M052802301	100	400
2.0	¾	M052802302	50	200
2.5	1	M052802303	25	150
3.2	1¼	M052802304	10	80
4.0	1½	M052802305	10	60
5.0	2	M052802306	5	30
6.5	2½	M052802307	5	20
8.0	3	M052802308	-	12
10.0	4	M052802309	-	06
15.0	6	M052802310	-	02
20.0	8	M052802311	-	01
25.0	10	817-100Ø	-	01
30.0	12	817-120Ø	-	01



Size (cm)	Size (inch)	Product Code	Pkg.(Nos.) Std. Mast.	
1.5	½	M052800501	50	300
2.0	¾	M052800502	50	200
2.5	1	M052800503	25	125
3.2	1¼	M052800504	10	60
4.0	1½	M052800505	10	50
5.0	2	M052800506	05	25
6.5	2½	M052800507	05	15
8.0	3	M052800508	-	10
10.0	4	M052800509	-	05
15.0	6	M052800510	-	02
20.0	8	M052800511	-	01
25.0	10	806-100Ø	-	01
30.0	12	806-120Ø	-	01

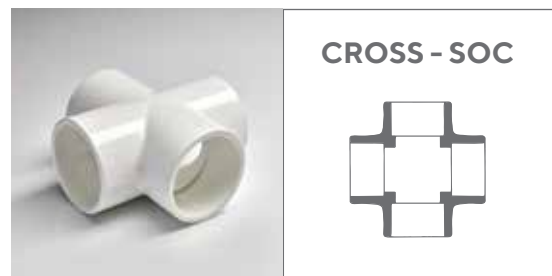

Size (cm)	Size (inch)	Product Code	Pkg.(Nos.) Std. Mast.	
1.5	½	M052802401	25	150
2.0	¾	M052802402	10	100
2.5	1	M052802403	10	50
3.2	1¼	M052802404	10	30
4.0	1½	M052802405	05	25
5.0	2	M052802406	-	15
6.5	2½	M052802407	-	09
8.0	3	M052802408	-	06
10.0	4	M052802409	-	03
15.0	6	820-060FØ	-	01
20.0	8	820-080FØ	-	01

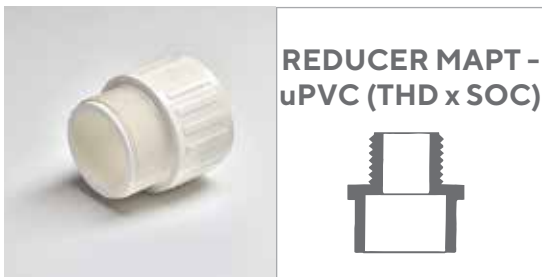

**REDUCER MAPT -
uPVC (THD x SOC)**

Size (cm)	Size (inch)	Product Code	Pkg.(Nos.) Std. Mast.	
2.0x1.5	¾ x ½	M052801314	50	400



TEE - SOC

Size (cm)	Size (inch)	Product Code	Pkg.(Nos.) Std. Mast.	
1.5	½	M052800101	50	200
2.0	¾	M052800102	25	125
2.5	1	M052800103	10	70
3.2	1¼	M052800104	10	40
4.0	1½	M052800105	05	30
5.0	2	M052800106	05	15
6.5	2½	M052800107	-	12
8.0	3	M052800108	-	07
10.0	4	M052800109	-	04
15.0	6	M052800110	-	02
20.0	8	M052800111	-	01
25.0	10	801-100Ø	-	01
30.0	12	801-120Ø	-	01



**REDUCER
ELBOW 90°
(SOC)**

Size (cm)	Size (inch)	Product Code	Pkg.(Nos.) Std. Mast.	
2.0 x 1.5	¾ x ½	M052800614	50	250
2.5 x 1.5	1 x ½	M052800615	25	150
2.5 x 2.0	1 x ¾	M052800616	25	150

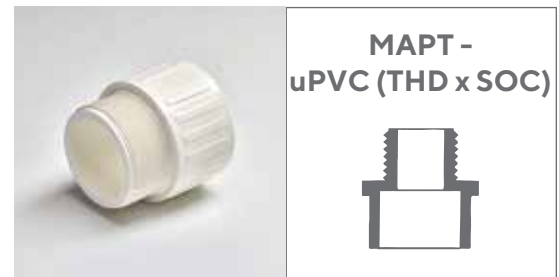

**MAPT -
uPVC (THD x SOC)**

Size (cm)	Size (inch)	Product Code	Pkg.(Nos.) Std. Mast.	
1.5	½	M052801301	100	600
2.0	¾	M052801302	50	400
2.5	1	M052801303	50	250
3.2	1¼	M052801304	10	150
4.0	1½	M052801305	10	100
5.0	2	M052801306	10	60
6.5	2½	M052801307	05	30
8.0	3	M052801308	05	20
10.0	4	M052801309	-	15
15.0	6	836-060Ø	-	01

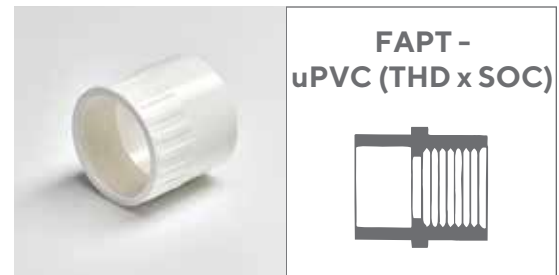

**FAPT -
uPVC (THD x SOC)**

Size (cm)	Size (inch)	Product Code	Pkg.(Nos.) Std. Mast.	
1.5	½	M052801601	100	600
2.0	¾	M052801602	50	400
2.5	1	M052801603	25	200
3.2	1¼	M052801604	10	100
4.0	1½	M052801605	10	80
5.0	2	M052801606	10	50
6.5	2½	M052801607	05	30
8.0	3	M052801608	05	20
10.0	4	M052801609	-	12
15.0	6	835-060Ø	-	01
20.0	8	835-080Ø	-	01

uPVC PRESSURE FITTINGS

SCHEDULE 80 AS PER ASTM D-2467

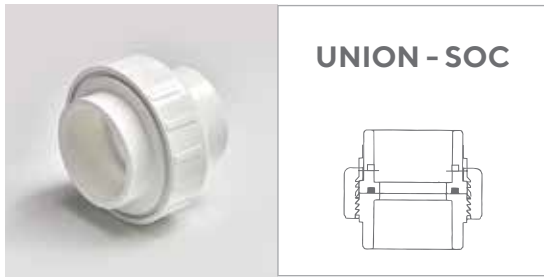

Size (cm)	Size (inch)	Product Code	Pkg.(Nos.) Std. Mast.	
1.5	½	M052802601	10	200
2.0	¾	M052802602	10	120
2.5	1	M052802603	10	80
3.2	1¼	M052802604	10	50
4.0	1½	M052802605	10	80
5.0	2	M052802606	05	30
6.5	2½	M052802607	-	15
8.0	3	M052802608	-	10
10.0	4	M052802609	-	04
15.0	6	8097-060Ø	-	01



Size (cm)	Size (inch)	Product Code	Pkg.(Nos.) Std. Mast.	
1.5	½	M052804101	100	800
2.0	¾	M052804102	50	500
2.5	1	M052804103	50	300
3.2	1¼	M052804104	10	150
4.0	1½	M052804105	10	100
5.0	2	M052804106	10	60
6.5	2½	M052804107	05	40
8.0	3	M052804108	05	25
10.0	4	M052804109	-	18
15.0	6	M052804110	-	15
20.0	8	847-080Ø	-	01
25.0	10	847-100FØ	-	01
30.0	12	847-120FØ	-	01



Size (cm)	Size (inch)	Product Code	Pkg.(Nos.) Std. Mast.	
1.5	½	M052806501	25	200
2.0	¾	M052806502	20	140
2.5	1	M052806503	20	80
3.2	1¼	M052806504	10	40
4.0	1½	M052806505	05	30
5.0	2	M052806506	05	20
6.5	2½	F052806507Ω	-	15
8.0	3	F052806508Ω	-	09



Size (cm)	Size (inch)	Product Code	Pkg.(Nos.) Std. Mast.	
2.0	¾	M0528010202	25	75
2.5	1	M0528010203	20	60
3.2	1¼	M0528010204	10	70
4.0	1½	M0528010205	10	60
5.0	2	M0528010206	05	35



Size (cm)	Size (inch)	Product Code	Pkg.(Nos.) Std. Mast.	
2.0	¾	M0528012702	100	600
2.5	1	M0528012703	50	350



Size (cm)	Size (inch)	Product Code	Pkg.(Nos.)	
			Std.	Mast.
2.0 x 1.5	¾ x ½	M052801114	50	300
2.5 x 1.5	1 x ½	M052801115	50	250
2.5 x 2.0	1 x ¾	M052801116	25	200
3.2 x 1.5	1¼ x ½	M052801117	25	150
3.2 x 2.0	1¼ x ¾	M052801118	20	140
3.2 x 2.5	1¼ x 1	M052801119	25	125
4.0 x 1.5	1½ x ½	M052801120	25	125
4.0 x 2.0	1½ x ¾	M052801121	25	100
4.0 x 2.5	1½ x 1	M052801122	25	100
4.0 x 3.2	1½ x 1¼	M052801123	10	80
5.0 x 1.5	2 x ½	M052801124	10	70
5.0 x 2.0	2 x ¾	M052801125	10	70
5.0 x 2.5	2 x 1	M052801126	15	75
5.0 x 3.2	2 x 1¼	M052801127	10	60
5.0 x 4.0	2 x 1½	M052801128	10	50
6.5 x 3.2	2½ x 1¼	M052801132	08	48
6.5 x 4.0	2½ x 1½	M052801133	05	40
6.5 x 5.0	2½ x 2	M052801134	05	40
8.0 x 3.2	3 x 1¼	M052801138	-	30
8.0 x 4.0	3 x 1½	M052801139	-	27
8.0 x 5.0	3 x 2	M052801140	05	25
8.0 x 6.5	3 x 2½	M052801141	05	25
10.0 x 4.0	4 x 1½	M052801146	-	03
10.0 x 5.0	4 x 2	M052801147	-	16
10.0 x 6.5	4 x 2½	M052801148	-	16
10.0 x 8.0	4 x 3	M052801149	-	15
15.0 x 5.0	6 x 2	M052801155	-	04
15.0 x 6.5	6 x 2½	M052801156	-	04
15.0 x 8.0	6 x 3	M052801157	-	04
15.0 x 10.0	6 x 4	M052801158	-	04
20.0 x 6.5	8x2½	A052801165*	-	01
20.0 x 8.0	8x3	A052801166*	-	01
20.0 x 10.0	8x4	M052801167*#	-	01
20.0 x 15.0	8 x 6	M052801168	-	02
25.0 x 10.0	10 x 4	829-624FØ	-	01
25.0 x 15.0	10 x 6	829-626Ø	-	01
25.0 x 20.0	10 x 8	829-628Ø	-	01
30.0 x 20.0	12 x 8	829-668Ø	-	01
30.0 x 25.0	12 x 10	829-670FØ	-	01



Size (cm)	Size (inch)	Product Code	Pkg.(Nos.)	
			Std.	Mast.
2.0 x 1.5	¾ x ½	M052800214	25	150
2.5 x 1.5	1 x ½	M052800215	25	100
2.5 x 2.0	1 x ¾	M052800216	25	100
3.2 x 1.5	1¼ x ½	M052800217	10	60
3.2 x 2.0	1¼ x ¾	M052800218	10	60
3.2 x 2.5	1¼ x 1	M052800219	10	50
4.0 x 1.5	1½ x ½	M052800220	10	40
4.0 x 2.0	1½ x ¾	M052800221	10	40
4.0 x 2.5	1½ x 1	M052800222	10	40
4.0 x 3.2	1½ x 1¼	M052800223	10	30
5.0 x 1.5	2 x ½	M052800224	05	30
5.0 x 2.0	2 x ¾	M052800225	05	25
5.0 x 2.5	2 x 1	M052800226	05	20
5.0 x 3.2	2 x 1¼	M052800227	05	20
5.0 x 4.0	2 x 1½	M052800228	05	20
6.5 x 1.5	2½ x ½	A052800229*	-	01
6.5 x 2.0	2½ x ¾	A052800230*	-	01
6.5 x 2.5	2½ x 1	M052800231	15	15
6.5 x 3.2	2½ x 1¼	M052800232	15	15
6.5 x 4.0	2½ x 1½	M052800233	15	15
6.5 x 5.0	2½ x 2	M052800234	12	12
8.0 x 1.5	3 x ½	A052800235*	-	01
8.0 x 2.0	3 x ¾	A052800236*	-	01
8.0 x 2.5	3 x 1	M052800237	10	10
8.0 x 3.2	3 x 1¼	M052800238	12	12
8.0 x 4.0	3 x 1½	M052800239	10	10
8.0 x 5.0	3 x 2	M052800240	09	09
8.0 x 6.5	3 x 2½	M052800241	09	09
10.0 x 1.5	4 x ½	A052800242*	-	01
10.0 x 2.0	4 x ¾	A052800243*#	-	01
10.0 x 2.5	4 x 1	M052800244	05	05
10.0 x 3.2	4 x 1¼	M052800245	05	05
10.0 x 4.0	4 x 1½	M052800246	05	05
10.0 x 5.0	4 x 2	M052800247	05	05
10.0 x 6.5	4 x 2½	M052800248	05	05
10.0 x 8.0	4 x 3	M052800249	05	05
15.0 x 5.0	6 x 2	M052800255	02	02
15.0 x 6.5	6 x 2½	M052800256	02	02
15.0 x 8.0	6 x 3	M052800257	02	02
15.0 x 10.0	6 x 4	M052800258	02	02
15.0 x 20.0	6 x 8	A0528002112*	-	01
20.0 x 10.0	8 x 4	M052800267	01	01
20.0 x 15.0	8 x 6	M052800268	01	01

All the items where product code starts with "F" are fabricated items and code starting with "A" are assembled items.
 * Trading items are in grey colour. # Shortly introducing
 SOC-SOCKET, SPG-SPIGOT, THD-THREADED

uPVC PRESSURE FITTINGS

SCHEDULE 80 AS PER ASTM D-2467

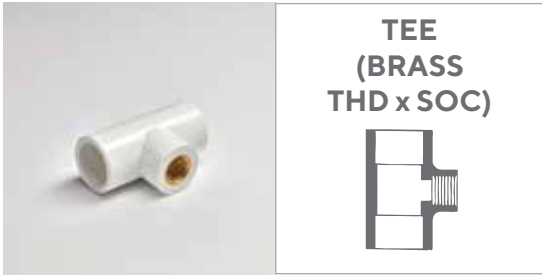

**TEE
(BRASS
THD x SOC)**

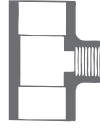

Size (cm)	Size (inch)	Product Code	Pkg.(Nos.) Std. Mast.	
1.5 x 1.5	½ x ½	M052800301	25	100
2.0 x 1.5	¾ x ½	M052800314	25	50
2.0 x 2.0	¾ x ¾	M052800302	25	50
2.5 x 1.5	1 x ½	M052800315	25	25
2.5 x 2.0	1 x ¾	M052800316	25	25
2.5 x 2.5	1 x 1	M052800303	10	30
3.2 x 1.5	1¼ x ½	M052800317	10	20



**ELBOW 90°
(BRASS
THD x SOC)**

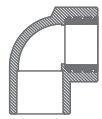

Size (cm)	Size (inch)	Product Code	Pkg.(Nos.) Std. Mast.	
1.5 x 1.5	½ x ½	M052800701	25	100
2.0 x 2.0	¾ x ¾	M052800702	25	75
2.5 x 2.5	1 x 1	M052800703	10	50



**REDUCER
ELBOW 90°
(BRASS THD x SOC)**

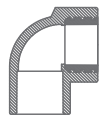

Size (cm)	Size (inch)	Product Code	Pkg.(Nos.) Std. Mast.	
2.0 x 1.5	¾ x ½	M052800714	25	100
2.5 x 1.5	1 x ½	M052800715	25	50
2.5 x 2.0	1 x ¾	M052800716#	-	50

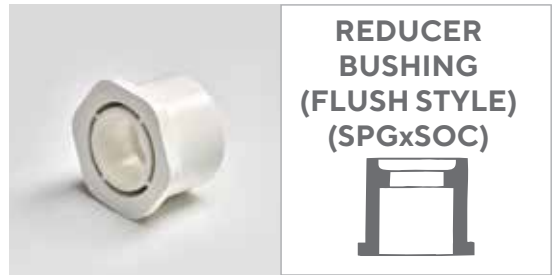

**REDUCER
BUSHING
(FLUSH STYLE)
(SPG x SOC)**



Size (cm)	Size (inch)	Product Code	Pkg.(Nos.) Std. Mast.	
2.0 x 1.5	¾ x ½	M052801914	100	300
2.5 x 1.5	1 x ½	M052801915	50	400
2.5 x 2.0	1 x ¾	M052801916	50	400
3.2 x 1.5	1¼ x ½	M052801917	25	250
3.2 x 2.0	1¼ x ¾	M052801918	25	250
3.2 x 2.5	1¼ x 1	M052801919	25	250
4.0 x 1.5	1½ x ½	M052801920	25	150
4.0 x 2.0	1½ x ¾	M052801921	25	150
4.0 x 2.5	1½ x 1	M052801922	25	150
4.0 x 3.2	1½ x 1¼	M052801923	25	150
5.0 x 1.5	2 x ½	M052801924	10	100
5.0 x 2.0	2 x ¾	M052801925	10	100
5.0 x 2.5	2 x 1	M052801926	10	100
5.0 x 3.2	2 x 1¼	M052801927	10	100
5.0 x 4.0	2 x 1½	M052801928	10	100
6.5 x 3.2	2½ x 1¼	M052801932	05	50
6.5 x 4.0	2½ x 1½	M052801933	05	50
6.5 x 5.0	2½ x 2	M052801934	05	50
8.0 x 2.5	3 x 1	A052801937*	-	01
8.0 x 3.2	3 x 1¼	M052801938	05	35
8.0 x 4.0	3 x 1½	M052801939	05	35
8.0 x 5.0	3 x 2	M052801940	05	35
8.0 x 6.5	3 x 2½	M052801941	05	35
10.0 x 4.0	4 x 1½	M052801946	05	20
10.0 x 5.0	4 x 2	M052801947	05	20
10.0 x 6.5	4 x 2½	M052801948	05	20
10.0 x 8.0	4 x 3	M052801949	05	20
15.0 x 8.0	6 x 3	M052801957	-	08
15.0 x 10.0	6 x 4	M052801958	-	06
20.0 x 10.0	8 x 4	M052801967	-	03
20.0 x 15.0	8 x 6	M052801968	-	03
25.0 x 10.0	10 x 4	837-624Ø	-	01
25.0 x 15.0	10 x 6	837-626Ø	-	01
25.0 x 20.0	10 x 8	837-628Ø	-	01
30.0 x 15.0	12 x 6	837-666FØ	-	01
30.0 x 20.0	12 x 8	837-668Ø	-	01
30.0 x 25.0	12 x 10	837-670Ø	-	01

* Trading Item. SOC-SOCKET # Shortly Introducing
All the items where product code starts with "F" are fabricated items.



Size (cm)	Size (inch)	Product Code	Pkg.(Nos.) Std. Mast.	
1.5	½	M052801401	50	150
2.0	¾	M052801402	25	100
2.5	1	M052801403	10	60
3.2	1¼	M052801404	10	50
4.0	1½	M052801405	10	40
5.0	2	M052801406	05	20
6.5	2½	M052801407	-	09
8.0	3	M052801408	-	08
10.0	4	M052801409	-	04



Size (cm)	Size (inch)	Product Code	Pkg.(Nos.) Std. Mast.	
2.0 x 1.5	¾ x ½	M052801714	25	150
2.5 x 1.5	1 x ½	M052801215	25	100
2.5 x 2.0	1 x ¾	M052801216	25	100



Size (cm)	Size (inch)	Product Code	Pkg.(Nos.) Std. Mast.	
2.0 x 1.5	¾ x ½	M052801414	25	125
2.5 x 1.5	1 x ½	M052801415	25	75
2.5 x 2.0	1 x ¾	M052801416	25	75

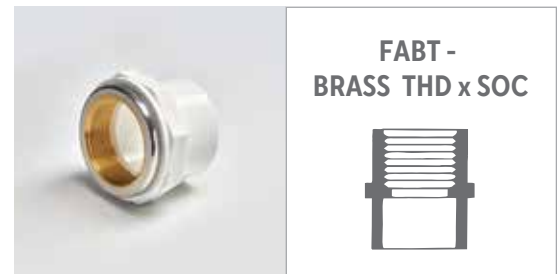

Size (cm)	Size (inch)	Product Code	Pkg.(Nos.) Std. Mast.	
1.5	½	M052801701	25	100
2.0	¾	M052801702	25	100
2.5	1	M052801703	25	50
3.2	1¼	M052801704	10	40
4.0	1½	M052801705	10	30
5.0	2	M052801706	05	15
6.5	2½	M052801707	-	09
8.0	3	M052801708	-	07
10.0	4	M052801709	-	06

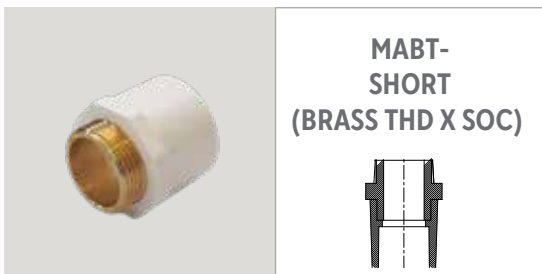

Size (cm)	Size (inch)	Product Code	Pkg.(Nos.) Std. Mast.	
3.2	1¼	M052801404ST	10	50



Size (cm)	Size (inch)	Product Code	Pkg.(Nos.) Std. Mast.	
2.5 x 1.5	1 x ½	M052802015	50	250

uPVC PRESSURE FITTINGS

SCHEDULE 80 AS PER ASTM D-2467



**STEP OVER
BEND (SOC)**

Size (cm)	Size (inch)	Product Code	Pkg.(Nos.) Std. Mast.
1.5	½	F052802801	- 90
2.0	¾	F052802802	- 60
2.5	1	F052802803	- 30
3.2	1¼	F052802804	- 25
4.0	1½	F052802805	- 20
5.0	2	F052802806	- 10



**LONG RADIUS
BEND 90° (SOC)**

Size (cm)	Size (inch)	Product Code	Pkg.(Nos.) Std. Mast.
1.5	½	F052800901	- 120
2.0	¾	F052800902	- 85
2.5	1	F052800903	- 50
3.2	1¼	F052800904	- 35
4.0	1½	F052800905	- 18
5.0	2	F052800906	- 12
6.5	2½	F052800907	- 06
8.0	3	F052800908	- 05
10.0	4	F052800909	- 04
15.0	6	F052800910	- 01

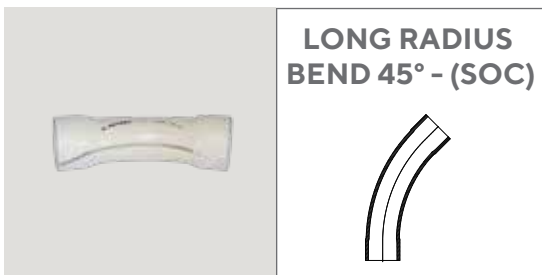

**LONG RADIUS
BEND 45° - (SOC)**

Size (cm)	Size (inch)	Product Code	Pkg.(Nos.) Std. Mast.
10.0	4	F052802309	- -



**VANSTONE
FLANGE - SOC**

Size (cm)	Size (inch)	Product Code	Pkg.(Nos.) Std. Mast.
1.5	½	M052803401	10 120
2.0	¾	M052803402	10 80
2.5	1	M052803403	10 60
3.2	1¼	M052803404	05 50
4.0	1½	M052803405	05 35
5.0	2	M052803406	05 25
6.5	2½	M052803407	- 15
8.0	3	M052803408	- 12
10.0	4	M052803409	- 08
15.0	6	M052803410	- 03
20.0	8	M052803411	- 01
25.0	10	854-100Ø	- 01
30.0	12	854-120Ø	- 01



**VANSTONE
FLANGE - SPG**

Size (cm)	Size (inch)	Product Code	Pkg.(Nos.) Std. Mast.
1.5	½	M052803301	10 120
2.0	¾	M052803302	10 80
2.5	1	M052803303	10 60
3.2	1¼	M052803304	5 50
4.0	1½	M052803305	5 35
5.0	2	M052803306	5 20
6.5	2½	M052803307	- 01
8.0	3	M052803308	- 16
10.0	4	M052803309	- 06
15.0	6	856-060Ø	- 01



Size (cm)	Size (inch)	Product Code	Pkg.(Nos.) Std. Mast.
1.5	½	M052803601	- 01
2.0	¾	M052803602	- 01
2.5	1	M052803603	- 01
3.2	1¼	M052803604	- 01
4.0	1½	M052803605	- 01
5.0	2	M052803606	- 01
6.5	2½	M052803607	- 01
8.0	3	M052803608	- 01
10.0	4	M052803609	- 01
15.0	6	M052803610	- 01
20.0	8	M052803611	- 01



Size (cm)	Size (inch)	Product Code	Pkg.(Nos.) Std. Mast.
1.5	½	M052804201	- 01
2.0	¾	M052804202	- 01
2.5	1	M052804203	- 01
3.2	1¼	M052804204	- 01
4.0	1½	M052804205	- 01
5.0	2	M052804206	- 01
6.5	2½	M052804207	- 01
8.0	3	M052804208	- 01
10.0	4	M052804209	- 01
15.0	6	M052804210	- 01
20.0	8	M052804211	- 01



Size (cm)	Size (inch)	Product Code	Pkg.(Nos.) Std. Mast.
6.5	2½	853-025Ø	- 01
8.0	3	M052803108	- 20
10.0	4	M052803109	- 12
15.0	6	853-060Ø	- 01



Size (cm)	Size (inch)	Product Code	Pkg.(Nos.) Std. Mast.
8.0	3	M052803208	- 12
10.0	4	M052803209	- 08

uPVC PRESSURE FITTINGS

SCHEDULE 80 AS PER ASTM D-2467



Size (cm)	Size (inch)	Product Code	Pkg.(Nos.) Std. Mast.	
1.5	½	M052803701#	-	01
2.0	¾	M052803702#	-	01
2.5	1	M052803703#	-	01
3.2	1¼	M052803704#	-	01
4.0	1½	M052803705#	-	01
5.0	2	M052803706#	-	01
6.5	2½	M052803707#	-	01
8.0	3	M052803708	-	01
10.0	4	M052803709	-	01



Size (cm)	Size (inch)	Product Code	Pkg.(Nos.) Std. Mast.	
1.5	½	M052802701N	01	120
2.0	¾	M052802702N	01	80
2.5	1	M052802703N	01	50
3.2	1¼	M052802704N	01	35
4.0	1½	M052802705N	01	20
5.0	2	M052802706N	01	12

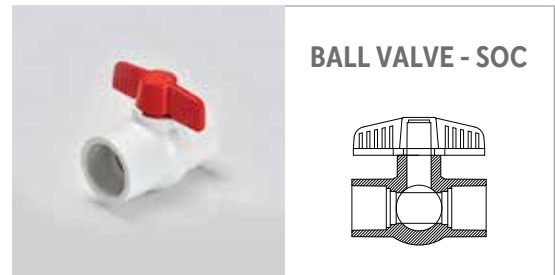

Size (cm)	Size (inch)	Product Code	Pkg.(Nos.) Std. Mast.	
6.5	2½	910-171Ø	-	12
8.0	3	910-181Ø	-	12
10.0	4	910-201Ø	-	06

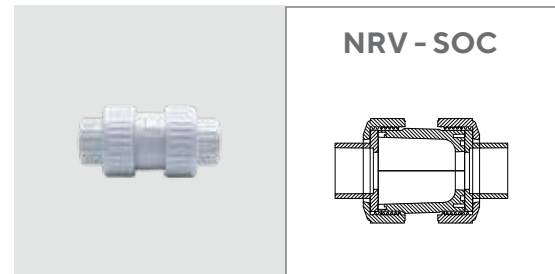

Size (cm)	Size (inch)	Product Code	Pkg.(Nos.) Std. Mast.	
2.0	¾	M0528013902	01	60
2.5	1	M0528013903	01	40

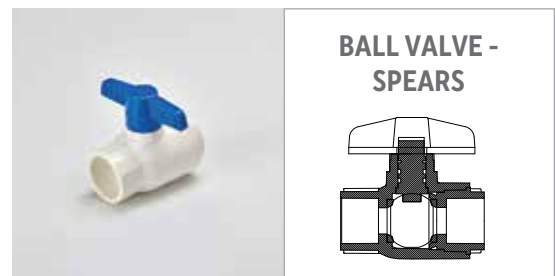

Size (cm)	Size (inch)	Product Code	Pkg.(Nos.) Std. Mast.	
6.5	2½	2622-025Ø	-	05
8.0	3	2622-030Ø	-	03
10.0	4	2622-040Ø	-	01
15.0	6	2622-060Ø	-	01

Note: Ball Valves rated working pressure is 150 psi (10 kgf/cm²) at 23°C
 SOC-SOCKET, SPG-SPIGOT * Trading Item. # Shortly Introducing

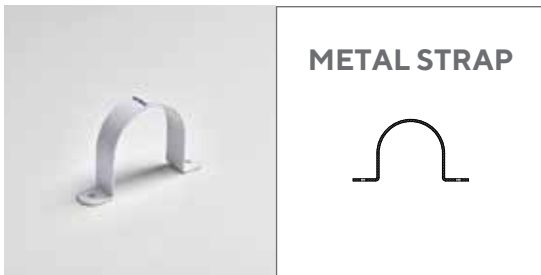

METAL STRAP



Size (cm)	Size (inch)	Product Code	Pkg.(Nos.) Std. Mast.
1.5	½	PVC9120MØ	- 800
2.0	¾	PVC9340MØ	- 500
2.5	1	PVC9100MØ	- 400
3.2	1¼	PVC9105MØ	- 300
4.0	1½	PVC9106MØ	- 250
5.0	2	PVC9200MØ	- 200



METAL STRAP (SS)



Size (cm)	Size (inch)	Product Code	Pkg.(Nos.) Std. Mast.
1.5	½	PVC9120MSS	180 1800
2.0	¾	PVC9340MSS	150 1500
2.5	1	PVC9100MSS	100 1000
3.2	1¼	PVC9105MSS	90 900
4.0	1½	PVC9106MSS	70 700
5.0	2	PVC9200MSS	50 500



uPVC SOLVENT CEMENT & PRIMER



**uPVC 705
MEDIUM BODIED**
(Suitable for 1/2" to
2"-Sch 40 & Sch 80)

Qty. (ml)	Product Code	Pkg.(Nos.) Std. Mast.
50	M008101015	- 48
118	M008101020	- 24
237	M008101025	- 24
473	M008101030	- 12
946	M008101035	- 12



**uPVC 735
MEDIUM BODIED**
(Suitable for Repair
Joint for Fast Set &
Cure for all sizes & types)

Qty. (ml)	Product Code	Pkg.(Nos.) Std. Mast.
473	MIPS473P735	- 12
946	MIPS946P735	- 12



**P-70 PRIMER
MEDIUM BODIED**
(Require for 2 1/2" to
12"-Sch 40 & Sch 80)

Qty. (ml)	Product Code	Pkg.(Nos.) Std. Mast.
473	M008401005	- 12
946	M008401010	- 12



**uPVC 717
HEAVY BODIED**
(Suitable for 2 1/2" to
12"-Sch 40 & Sch 80)

Qty. (ml)	Product Code	Pkg.(Nos.) Std. Mast.
473	M008201005	- 12
946	M008201010	- 12



**PIPEFIX
uPVC 206**
(Suitable for 1/2" to
2"-Sch 40 & Sch 80)

Qty. (ml)	Product Code	Pkg.(Nos.) Std. Mast.
50	M003607005	- 48
118	M003607010	- 24
237	M003607015	- 24
473	M003607020	- 12
946	M003607025	- 12



RESCUE TAPE

Size (ft.)	Product Code	Pkg.(Nos.) Std. Mast.
5	M005601010	- 120
5	M005601015	- 120
5	M005601005	- 120
10	M005601025	- 120
10	M005601030	- 120
10	M005601020	- 120
15	M005601040	- 120
15	M005601045	- 120
15	M005601035	- 120

ANCILLARY PRODUCTS

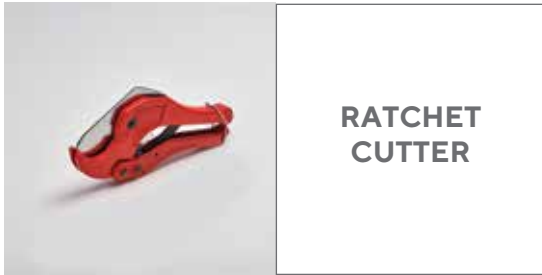

RATCHET CUTTER

Size (cm)	Size (inch)	Product Code	Pkg.(Nos.) Std. Mast.
1.5 - 3.2	½ - 1¼	TTOOLS-1Ø	- 01

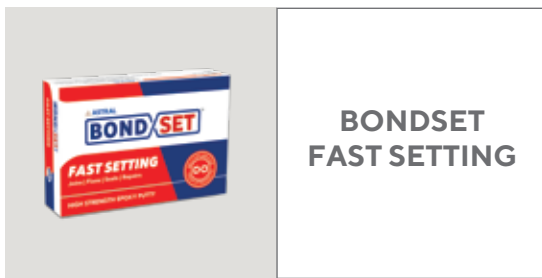

BONDSET FAST SETTING

Qty. (ml)	Product Code	Pkg.(Nos.) Std. Mast.
50	M000702051	- 01
100	M000702050	- 01



RESI-SHIELD

Qty. (ml)	Product Code	Pkg.(Nos.) Std. Mast.
100ML	RESI-SHIELD-100ML	- 100
200ML	RESI-SHIELD-200ML	- 50
500ML	RESI-SHIELD-500ML	- 25
1 L	RESI-SHIELD-1L	- 12
5 L	RESI-SHIELD-5L	- 03
20 L	RESI-SHIELD-20L	- 01



PTFE TAPE (12 MM WIDTH)

Qty. (ml)	Product Code	Pkg.(Nos.) Std. Mast.
4	M003302004	- 01
8	M003302007	- 01
8	M003302017	- 01

* Trading Item



Carrying Capacity and Friction Loss for Schedule 80 Thermoplastic Pipe

(Independent Variables : Gallons per minute and nominal pipe size O.D.

Dependent Variables : Velocity, friction head and pressure drop per 100 feet of pipe, interior smooth.)

Gallons per Minute	1/2 INCH			3/4 INCH			1 INCH			1 1/4 INCH			1 1/2 INCH			2 INCH			2 1/2 INCH		
	Flow Velocity (Feet Per Second)	Friction Head Loss (Ft Water/100Ft)	Friction Pressure Loss (PSI/100Ft)	Maximum Surge Pressure (PSI)	Flow Velocity (Feet Per Second)	Friction Head Loss (Ft Water/100Ft)	Friction Pressure Loss (PSI/100Ft)	Maximum Surge Pressure (PSI)	Flow Velocity (Feet Per Second)	Friction Head Loss (Ft Water/100Ft)	Friction Pressure Loss (PSI/100Ft)	Maximum Surge Pressure (PSI)	Flow Velocity (Feet Per Second)	Friction Head Loss (Ft Water/100Ft)	Friction Pressure Loss (PSI/100Ft)	Maximum Surge Pressure (PSI)	Flow Velocity (Feet Per Second)	Friction Head Loss (Ft Water/100Ft)	Friction Pressure Loss (PSI/100Ft)	Maximum Surge Pressure (PSI)	
1	1.465	2.198	0.950	44.100	0.779	0.473	0.205	21.570	1.402	1.048	0.451	37.290	0.277	0.248	0.107	19.04	0.562	0.113	0.049	13.161	
3	4.395	16.816	7.289	132.300	2.338	3.619	1.564	64.710	2.336	2.686	1.161	62.150	1.295	0.639	0.276	31.735	0.937	0.291	0.126	21.935	
5	7.326	43.310	18.720	220.500	3.896	9.322	4.029	107.800	3.271	5.008	2.165	87.010	1.812	1.191	0.515	44.429	1.312	0.548	0.235	30.709	
7	10.256	80.763	34.910	308.700	5.455	17.383	7.514	150.900	4.205	7.977	3.448	111.870	2.330	1.898	0.820	57.123	1.687	0.865	0.374	39.483	
9	0.498	0.042	0.018	105.00	7.792	33.652	14.546	215.700	4.672	9.696	4.191	124.300	2.589	2.305	0.997	63.47	1.875	1.052	0.455	43.870	
10	0.747	0.089	0.088	15.750	7.000	205.45	8.880	186.450	7.000	205.45	8.880	186.450	3.884	4.887	2.112	95.205	1.875	2.228	0.963	65.805	
15	0.996	0.151	0.065	21.000	9.344	350.02	15.129	248.600	9.344	350.02	15.129	248.600	5.178	8.326	3.599	126.940	2.750	3.797	1.64	87.740	
20	1.245	0.228	0.099	26.250	0.712	0.059	0.025	14.025	6.473	12.587	5.441	158.675	4.687	5.739	2.481	109.675	2.790	1.625	0.702	60.925	
25	1.494	0.320	0.138	31.500	0.855	0.082	0.036	16.830	7.768	17.642	7.626	190.410	5.825	8.045	3.477	131.610	3.348	2.278	0.985	73.110	
30	1.743	0.425	0.184	36.750	0.997	0.109	0.047	19.635	9.062	23.472	10.146	222.145	6.562	10.703	4.626	153.545	3.906	3.078	1.310	85.295	
35	1.992	0.545	0.235	42.000	1.140	0.140	0.061	22.440	10.357	30.057	12.992	253.880	7.499	13.705	5.924	175.480	4.445	3.88	1.677	97.480	
40	2.241	0.678	0.293	47.250	1.282	0.174	0.075	25.245	8.437	17.046	7.368	197.415	5.023	4.827	2.08	109.665	3.503	2.016	1.621	0.701	
45	2.490	0.823	0.356	52.500	1.425	0.212	0.092	28.050	0.627	0.022	0.012	11.500	9.374	20.719	8.955	219.350	5.581	5.866	2.536	121.850	
50	2.988	1.154	0.499	63.000	1.710	0.297	0.128	33.660	0.752	0.040	0.017	13.800	11.249	29.04	12.558	263.220	6.697	8.223	3.554	146.220	
60	3.486	1.536	0.664	73.500	1.995	0.395	0.171	39.270	0.877	0.054	0.023	16.100	8.929	14.009	6.055	194.960	6.237	5.851	2.529	139.120	
70	3.984	1.968	0.850	84.000	2.280	0.506	0.219	44.880	1.000	0.069	0.030	18.400	10.045	17.424	7.531	219.330	7.016	7.277	3.146	173.900	
80	4.482	2.446	1.057	94.500	2.565	0.629	0.272	50.490	1.128	0.085	0.037	20.700	11.161	21.178	9.154	243.700	7.796	8.845	3.823	173.900	
90	4.980	2.973	1.285	105.000	2.850	0.765	0.330	56.100	1.253	0.104	0.045	23.000	10.045	17.424	7.531	219.330	7.016	7.277	3.146	173.900	
100	5.478	3.500	1.533	115.500	3.135	0.915	0.405	61.650	1.377	0.122	0.053	25.200	11.161	21.178	9.154	243.700	7.796	8.845	3.823	173.900	
125	6.225	4.494	1.943	131.250	3.562	1.156	0.500	70.125	1.567	0.157	0.068	28.750	0.892	0.040	0.017	15.375	1.249	0.032	0.014	15.200	
150	7.469	6.229	2.723	157.500	4.274	1.620	0.700	84.150	1.880	0.220	0.095	34.500	1.07	0.055	0.024	18.450	1.360	0.067	0.022	22.800	
175	8.714	8.381	3.622	183.750	4.987	2.155	0.932	98.175	2.193	0.292	0.126	40.250	1.249	0.074	0.032	21.525	1.481	0.089	0.033	26.600	
200	9.959	10.732	4.639	210.000	5.699	2.760	1.193	112.200	2.560	0.374	0.162	46.000	1.427	0.095	0.04	24.600	1.600	0.114	0.044	30.400	
250					7.124	4.173	1.804	140.250	3.133	0.566	0.244	57.500	1.784	0.144	0.062	30.750	1.933	0.133	0.048	34.200	
300					8.549	5.849	2.528	168.300	3.760	0.793	0.343	69.000	2.141	0.202	0.087	36.900	2.260	0.160	0.052	38.000	
350					9.974	7.781	3.363	196.350	4.386	1.055	0.455	80.500	2.498	0.268	0.116	43.050	2.587	0.187	0.058	41.850	
400									5.013	1.351	0.581	92.000	2.855	0.348	0.148	49.200	2.913	0.214	0.064	45.600	
450									5.639	1.680	0.728	103.500	3.212	0.427	0.185	55.350	3.240	0.240	0.074	49.350	
500									6.266	2.042	0.888	115.000	3.589	0.519	0.224	61.500	3.567	0.274	0.084	53.100	
750									9.399	4.327	1.870	172.500	5.353	1.100	0.475	92.250	3.400	0.365	0.158	57.000	
1000									7.137	1.874	0.810	123.000	4.533	0.621	0.269	76.000	3.202	0.267	0.115	53.000	
1250									8.921	2.833	1.224	153.750	5.667	0.939	0.405	95.000	4.003	0.403	0.174	66.250	
1500									10.706	3.970	1.716	184.500	6.800	1.316	0.569	114.000	4.803	0.585	0.244	79.500	
1750									12.491	5.107	2.607	215.250	8.000	1.751	0.757	133.000	5.604	0.752	0.325	92.750	
2000									14.276	6.248	3.508	246.000	9.200	2.248	0.969	152.000	6.404	0.968	0.416	106.000	

CAUTION: Flow velocity should not exceed 5 feet per second. PVC pipe cannot be used for compressed air service.

EXPANSION AND CONTRACTION OF uPVC PIPE

CARRYING CAPACITY AND FRICTION LOSS FOR SCHEDULE 80 THERMOPLASTIC PIPE

uPVC pipes, like other piping materials, undergoes length changes as a result of temperature variations above and below the installation temperature. They expand and contract 4.5 to 5 times more than steel or iron pipe. The extent of the expansion - contraction depends upon the coefficient of linear expansion of piping material. The length of pipe between directional changes, and the temperature differential.

The coefficient of thermal expansion (Y) for uPVC is 3.1×10^{-5} in./in./°F.

The amount of expansion and contraction can be calculated using the following formula:

$$\Delta L = Y(T_1 - T_2) \times L$$

ΔL = Dimensional change due to thermal expansion or contraction (Inch)

Y = Expansion coefficient (in./in./°F)

$(T_1 - T_2)$ = Temperature differential between the installation temperature and the maximum or minimum system temperature, whichever provides the greatest differential (°F).

L = Length of pipe run between changes in direction (in).

There are several ways to compensate for expansion and contraction. The most common method are:

1. Expansion loops which consist of pipe and 90° elbows.
2. Piston type expansion joints*
3. Flexible bends*
4. Bellows and rubber expansion joints*

* The manufacturers of these devices should be contacted to determine the suitability of their products for the specific application.

Expansion loops are a simple and convenient way to compensate for expansion and contraction when there is sufficient space for the loop in the piping system. A typical expansion loop design is shown below:

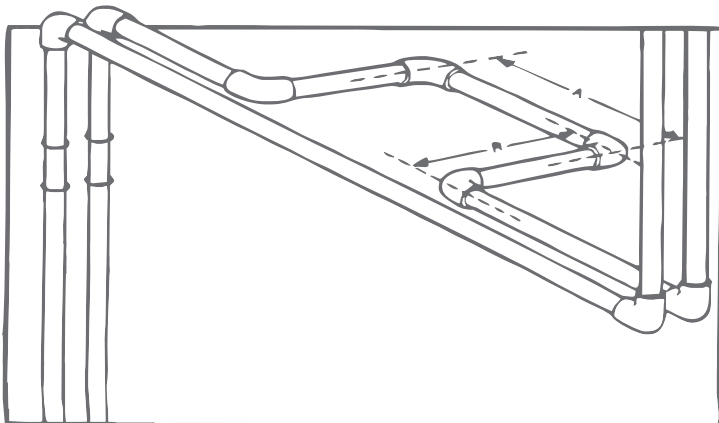

The length of leg "R" can be determined by using the following formula to ensure that it is long enough to absorb the expansion and contraction movement without damage. The length of leg "A" should be 1/2 the length of leg "R"

- R = 1.44 D Δ L
- R = Expansion loop leg length (ft)
- D = Nominal outside diameter of pipe (in.) (See table below.)
- ΔL = Dimensional change due to thermal expansion or contraction (in.)

When installing the expansion loop, no rigid or restraining supports should be placed within the leg lengths of the loop. The loop should be installed as closely as possible to the mid-point between anchors. Piping support guides should restrict lateral movement and direct axial movement into the loop. Lastly, the pipe and fittings should be solvent cemented together, rather than using threaded connections.

Compensation for expansion and contraction in underground application is normally achieved by snaking the pipe in the trench. Proper trenching and burial procedures must be followed to protect the piping system.

The table below shows recommended offsets & loop lengths for piping upto 2½ inches nominal sizes.

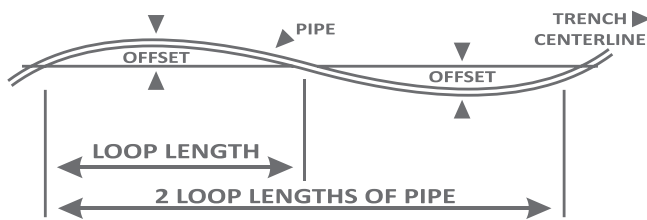

		Max. Temp. Variation °F, Between Installation and Final Operation									
		10°	20°	30°	40°	50°	60°	70°	80°	90°	100°
Loop Offset in Inches	Loop Length in Feet										
	20	3.0	3.5	4.5	5.0	6.0	6.5	7.0	7.0	8.0	8.0
50	7.0	9.0	11.0	13.0	14.0	15.5	17.0	18.0	19.0	20.0	
100	13.0	18.0	22.0	26.0	29.0	31.5	35.0	37.0	40.0	42.0	

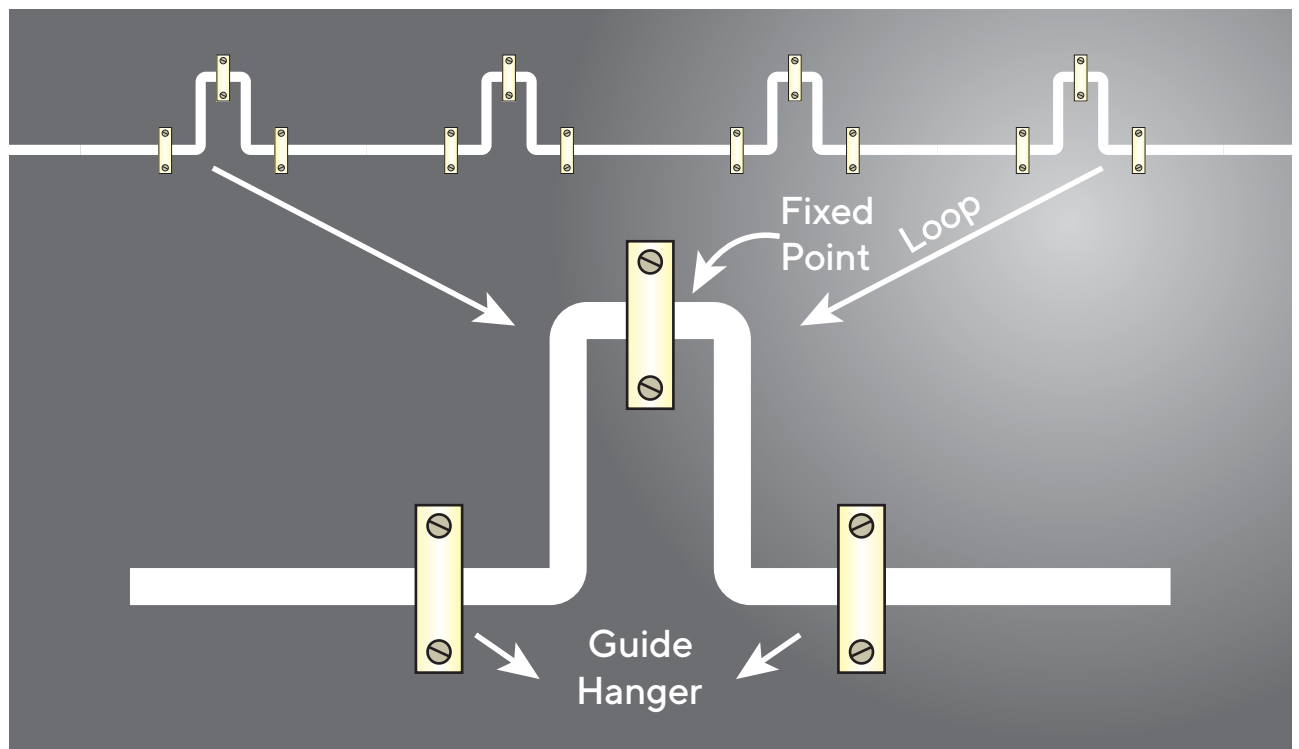

JOINT CURING

RECOMMENDED INITIAL SET TIMES

Temperature	Pipe Size	Pipe Size	Pipe Size	Pipe Size
Range	½" to 1¼"	½" to 3"	4" to 8"	10" to 12"
	15 to 32 mm	40 to 80 mm	100 to 200 mm	250 to 300 mm
15.5°C - 37.7°C	15 min.	30 min.	1 hr.	2 hrs.
4.4°C - 15.5°C	1 hr.	2 hrs.	4 hrs.	8 hrs.

RECOMMENDED INITIAL CURE TIMES

Temperature	Pipe Size	Pipe Size	Pipe Size	Pipe Size
Range	½" to 1¼"	½" to 3"	4" to 8"	10" to 12"
	15 to 32 mm	40 to 80 mm	100 to 200 mm	250 to 300 mm
15.5°C - 37.7°C	6 hrs.	12 hrs.	24 hrs.	48 hrs.
4.4°C - 15.5°C	12 hrs.	24 hrs.	48 hrs.	96 hrs.

SUPPORT SPACING FOR uPVC PIPE

Adequate supports for any piping system is a matter of great importance. In practice, support spacings are a function of pipe size operating temperatures, the location of heavy valves or fittings and the mechanical properties of the pipe material. To ensure the satisfactory operation of a ASTRAL Aquarius uPVC piping system, the location and type of hangers should be carefully considered. Hangers should not compress, distort, cut or abrade the piping.

All piping should be supported with an approved hanger at intervals sufficiently close to maintain correct pipe alignment and to prevent sagging or reversal. Pipe should also be supported at all branch ends and at all changes of direction. Support trap arms as close as possible to the trap. In keeping with good plumbing practices support and brace all closet bends and fasten closet angles.

1. Concentrated loads should be supported directly so as to eliminate high stress concentrations. Should this be impractical then the pipe must be supported immediately adjacent to the load.
2. In systems where large fluctuations in temperature occur, allowances must be made for expansion and contraction of the piping system. Since changes in direction in the system are usually sufficient to allow for expansion and contraction hangers must be placed so as not to restrict this movement.
3. Since plastic pipe expands or contracts approximately five times greater than those of steel, hangers should not restrict this movement.
4. Hangers should provide as much bearing surface as possible. To prevent damage to the pipe, file smooth any sharp edges or burrs on the hangers or supports.
5. Support spacing for horizontal piping systems is determined by the maximum operating temperature the system will encounter. The piping should be supported on uniform centers with supports that do not restrict the axial movement.
6. For vertical lines, it is recommended that an engineer should design the vertical supports according to the vertical load involved.



SCHEDULE - 40 RECOMMENDED SUPPORT SPACING (IN FEET)

Nom. Pipe Size		Temperature °C				
(in.)	(mm)					
-	-	15.5	26.6	37.7	48.8	60
½	15	4½	4½	4	2½	2½
¾	20	5	4½	4	2½	2½
1	25	5½	5	4½	3	2½
1¼	32	5½	5½	5	3	3
1½	40	6	5½	5	3½	3
2	50	6	5½	5	3½	3
2½	65	6½	6	5½	4	3
3	80	7	7	6	4	3½
4	100	7½	7	6½	4½	4
6	150	8½	8	7½	5	4½
8	200	9½	9	8½	5½	5
10	250	10½	9½	9	6½	5½
12	300	12	10½	9½	7	6

SCHEDULE - 80 RECOMMENDED SUPPORT SPACING (IN FEET)

Nom. Pipe Size		Temperature °C				
(in.)	(mm)					
-	-	15.5	26.6	37.7	48.8	60
½	15	5	4½	4½	3	2½
¾	20	5½	5	4½	3	2½
1	25	6	5½	5	3½	3
1¼	32	6	6	5½	3½	3
1½	40	6½	6	5½	3½	3½
2	50	7	6½	6	4	3½
2½	65	7½	7½	6½	4½	4
3	80	8	7½	7	4½	4
4	100	9	8½	7½	5	4½
6	150	10	9½	8½	6½	5½
8	200	11	10	9½	7½	6
10	250	12½	11	10½	7½	6½
12	300	13	12	10½	7½	6½

INSTALLATION PROCEDURE



1. CUT PIPE

- Cut pipe square. As joints are sealed at the base of the fitting socket. An angled cut may result in joint failure.
- Acceptable tools include miter saw, mechanical cut off saw or wheel cutter. Wheel type cutters must employ a blade designed for plastics.



2. REMOVE BURR & BEVEL

- Remove all burr from inside and outside of pipe with a knife-edge, file or deburring tool. Chamfer (bevel) the end of the pipe 10° -15°.
- Remove surface dirt, grease or moisture with a clean dry cloth.



3. DRY FIT

- With light pressure, pipe should go one third to one half of the way into the fitting socket. Pipes and Fittings that are too tight or too loose should not be used.



4. APPLICATOR

- Use an applicator that is one half the pipe diameter.
- Too large an applicator will force excessive cement into the inside of small diameter fittings. Too small an applicator will not apply sufficient cement to large diameter systems.

5. CEMENT

- Apply a full even layer of cement to the outside of a pipe and medium layer of cement to the inside of a fitting.



6. JOIN PIPE & FITTING

- Assemble pipe and fitting socket till it contacts socket bottom. Give pipe a quarter turn. Hold pipe and fitting together until the pipe does not back out.
- Remove excessive cement from the exterior. A properly made joint will show a continuous bead of cement around the perimeter.
- Observe all safety precautions.
- System should be installed in a good and workman like manner consistent with normal industry standards and in conformance with all local plumbing, fire and building code requirements. Failure to follow proper installation practices, procedures or techniques can result in system failure, property damage or personal injury.
- Pipes and fittings should be used for their intended purpose as defined by local plumbing and building codes and the applicable ASTM standards.
- Follow manufacturers instructions for all related products.



uPVC CEMENT FOR SCH 40 AND INTERFERENCE FIT

Pipe Size (in.) (mm)	Cement Type	Min. Vis. (cP)	IPS-Weld On
(1/2-2) (15-50)	Medium Bodied	500	705
(2 1/2-12) (65-300)	Heavy Bodied	2000	717

uPVC CEMENT FOR SCH 80 AND INTERFERENCE FIT

Pipe Size (in.) (mm)	Cement Type	Min. Vis. (cP)	IPS-Weld On
(1/2-2) (15-50)	Medium Bodied	500	705
(2 1/2-12) (65-300)	Heavy Bodied	2000	717

FLANGING OF ASTRAL AQUARIUS uPVC PIPE

Flanging can be used to provide temporary disassembly of a piping system or when it is not possible to make up solvent cemented joints at the assembly site. Flanges are joined to the pipe by solvent cement or threaded joints. Refer to the sections on solvent cementing or threading of Astral AQUARIUS uPVC pipe for the proper techniques. Flanged joints incorporate an elastomeric gasket between the mating faces to provide for a seal. The gasket selected must be full-faced and have a hardness of 55-80 durometer A. Typically, gaskets are 1/8" thick. The gasket material must be resistant to the chemical environment. Many manufacturers of gasketing materials supply this kind of information. If the piping system is for potable water service, the gasket must also be approved for potable water. The flanges should be carefully aligned and the bolts inserted through matching holes. A flat washer should be used beneath each nut and bolt head. Each bolt should be partially tightened in the alternating sequence indicated here. A torque wrench should be used for the final tightening of the bolts. The bolts should be tightened to the torque recommended as per the table in the same alternating sequence used previously. Flange joints are typically rated to 150 psi at 23°C. For systems operating at higher temperatures, the flange pressure rating should be derated with the same derating factors which apply to the piping system pressure rating.

TESTING PRESSURE SYSTEM

- Prior to testing, safety precautions should be instituted to protect personnel and property in case of test failure.
 - Conduct pressure testing with water. **DO NOT USE AIR OR OTHER GASES** for pressure testing.
 - The piping system should be adequately anchored to limit movement. Water under pressure exerts thrust forces in piping systems. Thrust blocking should be provided at changes of direction, change in size and at dead ends.
 - Please refer tables given for initial set & cure times before pressure testing.
 - The piping systems should be slowly filled with water, taking care to prevent surge and air entrapment. The flow velocity should not exceed 5 feet per second.
 - All trapped air must be slowly released. Vents must be provided at all high points of the piping system. All valves and air relief mechanisms should be opened so that the air can be vented while the system is extremely dangerous and it must be slowly and completely vented prior to testing. For sizes 4" & above, ASTRAL recommends to use automatic air relief valves at every 300-400mt. distance & at furthest & highest points of pipeline to avoid any damage to the piping system.
- The piping system can be pressurized to 125% of its designed working pressure. However care must be taken to ensure the pressure does not exceed the working pressure of the lowest rated component in the system (valves, unions, flanges, threaded parts etc.)
- The pressure test should not exceed one hour Any leaking joints or pipe must be cut out and replaced and the line recharged and retested using the same procedure.



UNDERGROUND INSTALLATION

uPVC pipes and fittings can be installed underground, Since these piping systems are flexible systems, proper attention should be given to burial conditions. The stiffness of the piping system is affected by sidewall support, soil compaction, and the condition of the trench, Trench bottoms should be smooth and regular in either undisturbed soil or a layer of compacted backfill. Pipe must lie evenly on this surface throughout the entire length of its barrel, Excavation, bedding and backfill should be in accordance with the provision of the local Plumbing Code having jurisdiction

TRENCHING

The following trenching and burial procedures should be used to protect the piping system.

1. The trench should be excavated to ensure the sides will be stable under all working conditions. The trench should be wide enough to provide adequate room for the following :
 - A. Joining the pipe in the trench.
 - B. Snaking the pipe from side or side to compensate for expansion and contraction.
 - C. Filling and compacting the side fills.

The space between the pipe and trench wall must be wider than the compaction equipment used in the compaction of the backfill. Minimum width shall not be less than the greater of either the pipe outside diameter plus 16 inches of the pipe outside diameter times 1.25 plus 12 inches. Trench width may be different if approved by the design engineer.

2. The trench bottom should be smooth, free of rocks and debris, continuous, and provide uniform support. If ledge rock, hardpan or large boulders are encountered, the trench bottom should be padded with bedding of compacted granular material to a thickness of at least 4 inches. Foundation bedding should be installed as required by the engineer.
3. Trench depth is determined by the pipe's service requirements. Plastic pipe should always be installed at least below the frost level. The minimum cover for lines subject to heavy overhead traffic is 24 inches.
4. A smooth, trench bottom is necessary to support the pipe over its entire length on firm stable material. Blocking should be used charge pipe grade or to intermittently support pipe over low sections in the trench.



BEDDING AND BACKFILLING

1. Even though sub-soil conditions vary widely from place to place, the pipe backfill should be stable and provide protection for the pipe.
2. The pipe should be surrounded with a granular material which is easily worked around the sides of the pipe. Backfilling should be performed in layer of 6 inch with each layer being sufficiently compacted to 85% to 95% compaction.
3. A mechanical tamper is recommended for compacting sand and gravel backfill which contain a significant proportion of fine grained material, such as silt and clay. If a tamper is not available, compacting should be done by hand.
4. The trench should be completely filled. The back fill should be placed and spread in fairly uniform layers to prevent any unfilled spaces or voids. Large rocks, stones, frozen clods, or other large debris should be removed. Heavy tampers or rolling equipment should only be used to consolidate only the final backfill.

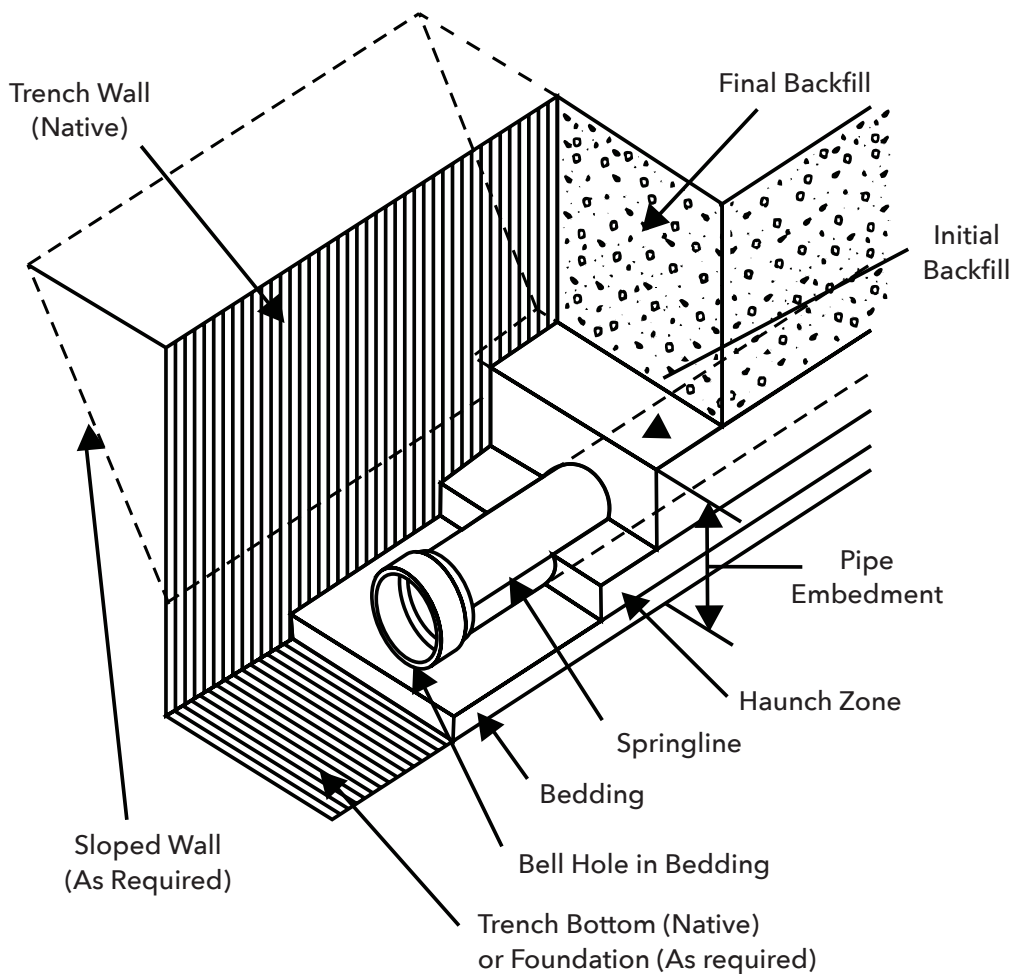

FIG. 1 Installation Terminology

HANDLING AND STORAGE

HANDLING

The pipe should be handled with reasonable care. Because thermoplastic pipe is much lighter in weight than metal pipe, there is sometimes a tendency to throw it around. This should be avoided.

The pipe should never be dragged or pushed from a truck bed. Pallets of the pipe should be removed with a fork lift. Loose pipe can be rolled down, as long as the pieces do not fall on each other or on any hard or uneven surface. In all cases, severe contact with any sharp objects (rocks, angle irons, forks on forklifts, etc.) should be avoided.

STORAGE

If possible, pipe should be stored inside. When this is not possible, the pipe should be stored on level ground which is dry and free from sharp objects. If different schedules of pipes are stacked together, the pipe with the thickest wall should be at the bottom.

The pipe should be protected from the sun and be in an area with proper ventilation. This will lessen the effects of ultraviolet rays and help prevent heat built-up.

If the pipe is stored in racks, it should be continuously supported along its length. If this is not possible, the spacing of the supports should not exceed three feet (3').

When storage temperatures are below 0°C (32°F), extra care should be taken when handling the pipe. This will help prevent any problems which could be caused by the slightly lower impact strength of uPVC pipe at temperature below freezing point.

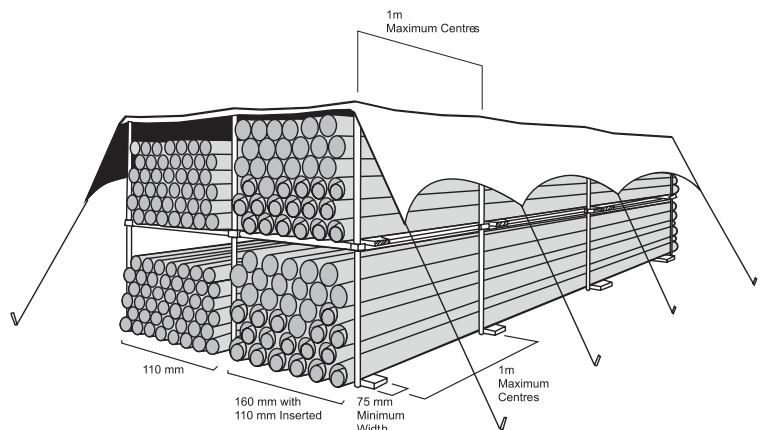

NOT FOR USE WITH COMPRESSED AIR OR GASES

ASTRAL POLY TECHNIK LTD. DOES NOT RECOMMEND the use of thermoplastic piping products for systems to transport or store compressed air or gases, or the testing of thermoplastic piping systems with compressed air or gases in above as well as below ground locations, The use of ASTRAL Aquarius product in compressed air or gas systems automatically void any warranty for such products and its use against our recommendation is entirely the responsibility and liability of the installer.

WARNING: Do not use compressed air or gas to test any PVC thermoplastic piping product or system, and do not use devices propelled by compressed air or gas to clear systems. These practices may result in explosive fragmentation of system piping components causing serious or fatal bodily injury.

FREQUENTLY ASKED QUESTIONS (FAQs)

WHY LEAD-FREE?

Lead is a metal with no known biological benefit to humans. Too much lead can damage various systems of the body including the nervous and reproductive systems and the kidneys, and it can cause high blood pressure and anemia. Lead accumulates in the bones and lead poisoning may be diagnosed from a blue line around the gums. Lead is especially harmful to the developing brains of fetuses and young children and to pregnant women. Lead interferes with the metabolism of calcium and Vitamin D. High blood lead levels in children can cause consequences which may be irreversible including learning disabilities, behavioral problems, and mental retardation. At very high levels, lead can cause convulsions, coma and death. Lead can be dissolved in water when lead pipes are used for transportation of water. So use of such pipes may be harmful to human being. Hence lead free plumbing system is most favoured for potable water transportation.

WHAT IS THE EXPECTED LIFE OF ASTRAL AQUARIUS SYSTEM?

ASTRAL Aquarius uPVC system design & standards incorporate significant engineering safety factors which should translate to a long service life. ASTRAL Aquarius system have a design service life span of 50 years. ASTRAL Aquarius system is not susceptible to corrosion, scale build up or electrolysis in areas where water, solid and / or atmospheric conditions are aggressive. ASTRAL firmly believes that the system will provide a service life as long or longer than alternative materials in the market.

WILL ASTRAL AQUARIUS SYSTEM SAVE MY MONEY?

Yes, as a professional, you will quickly realize that uPVC can be installed at least 25% more quickly than metal systems. Financial savings are also realized with regard to lower tool costs and insurance advantage. Even considering the frequent rise and fall of the metal price structure, uPVC offers a continuing material cost advantage, as much as a full 50-60% material savings today.

WILL ASTRAL AQUARIUS SYSTEM OFFER A FINANCIAL ADVANTAGE TO OWNERS IN TERMS OF UTILITIES EXPENSE?

Yes, the thermal conductivity of a metal system is 2500 times that of a uPVC system. The improved insulating characteristics associated with uPVC can generate long term saving for energy conscious owner. ASTRAL Aquarius will hold the temperature of water for a much longer period of time than metal tubing.

MUST I USE PLASTIC INSULATORS WHEREVER uPVC PASSES THROUGH A STUD?

Technically, no such provision need to be made when passing through wood stud. When passing through metal studs some form of protection must be used to protect the pipe from abrasion and to prevent noise. This protection may come from plastic insulated rubber grommets, pipe insulation or similar.

SHOULD SPECIFIC TYPE OF PRIMERS AND SOLVENT CEMENTS BE USED ONPVC SYSTEM?

ASTRAL always recommends use of solvent cement which is specifically manufactured to meet the requirements of ASTM D 2564. All purpose solvent cement should not be utilized. Primers manufactured for uPVC pipe is acceptable. For more details, refer installation procedure in this manual.

I HAVE BEEN TOLD THAT UPVC PIPING ENDS MAY SPLIT DURING INSTALLATION. WHY DOES THIS OCCUR? HOW CAN THESE CRACKS BE PREVENTED?

Most cracks are initiated by rough handling. This handling can occur during transportation, while being inventoried at the wholesaler, or while at the job sight. Also, Fine cracks can be caused by cutting the pipe with dull or damaged ratchet cutters. The vast majority cracks occur during colder weather months when temperature is below 10°C, uPVC

like most other plastics such as PP, PEX, CPVC, may become somewhat brittle and should be handled more carefully. To reduce problems resulting from cracked product, several measures can be initiated : (A) Educate your installers. Make them aware of the potential problems and instruct them to handle uPVC in a appropriate way. (B) Use a saw or a circular tubing cutter with a plastic tubing blade to cut your pipe to length. (C) Inspect pipe ends thoroughly prior to making a joint. Should a crack be evident, cut off any split portion before proceeding. (D) During cold weather, gripping the pipe surrounding the area to be cut for about 10 seconds prior to making the cut will warm the pipe and reduce possible problems.

WHAT ABOUT HEALTH, SAFETY & FIRE TOXICITY ISSUES?

Tests performed at respected universities and independent laboratories confirm that uPVC is superior to metal systems in terms of water quality effects and "no more toxic than wood" in fi re. ASTRAL Aquarius uPVC system is manufactured from a compound which is lead free and hence most favoured system in terms of health and safety. LOI(LIMITING OXYGEN INDEX) of uPVC is 45, which means uPVC is not reality burnable in atmosphere. Once the burning source is removed, It stops burning, because of self extinguishing nature of uPVC.

IS ASTRAL AQUARIUS SYSTEM RESISTANT TO U.V. EXPOSURE?

Effect of U.V. on polymers: U.V. acts as a strong catalyst for the oxidations process which breaks down the polymer chains, leading weakness in the pipes & fittings and to loss of hydrostatic strength. "Above effect is very much possible with materials like PP & PE. But for uPVC main process is dehydrochlorination and not oxidation. This dehydrochlorination does not break down the polymer chains to any significant extent after outdoor exposure, being mainly limited to a surface discoloration effect only. There is a loss of impact resistance due to impact modifiers losing their efficiency. This may even result in increased modulus. There is no significant loss in stress bearing capacity impact resistance mainly an installation issue (before any U.V. exposure). Still if a portion of the piping system will be left exposed to U.V. light, a standard grade of exterior, latex paint (water base) will protect the pipe adequately.

IS IT POSSIBLE TO USE ASTRAL AQUARIUS SYSTEM AT TEMPERATURE AROUND 10-15°C?

Practically, Yes. It is very much possible to use ASTRAL Aquarius at a temperature around 10-15°C. Normal temperature range of uPVC compound material is 23°C to 60°C. As temperature decrease beyond 23°C, uPVC becomes brittle like any other thermoplastic material. So it's impact properties decreases as temperature decreases but there is no reduction in hydrostatic strength of material at lower temperatures, So it can be used at lower temperatures but very sound engineering design considerations required at a such low temperatures to eliminate water hammers & impact issues.

WHAT ABOUT THE NOISE EMISSIONS COMPARE TO METALLIC SYSTEM?

The tendency of sound is to travel in the material with fastest possible velocity. This means in the metal system, the sound travels because the velocity of sound in metal is higher than that of in water and create noise emissions. While in uPVC system, noise will travel in water because the velocity of sound in water is higher than that of in uPVC. So uPVC systems are as quiet as physically possible.

WHAT ABOUT SCALE BUILT UP?

Scale built up is a function of the roughness of the pipe, as measured by the Hazen - Williams, "C" factor, used in the Hazen Williams formula for calculating friction head losses in piping system.

Higher value for C results in - less friction, less head loss. In metal systems, once corrosion starts, "C" factor will greatly reduce which results in head loss and scale built up. With ASTRAL Aquarius uPVC, there is no corrosion and hence scale built up is inhibited.

IS IT POSSIBLE TO CONNECT IPS SYSTEM WITH CTS SYSTEM?

IPS (Iron Pipe Size) & CTS (Copper Tube Size) are most widely used systems in plumbing market. Therefore changeability of one to another is very important. ASTRAL has understood this requirement of market and hence developed special transition fittings. These fittings will connect the IPS System (SCH 40 & SCH 80) to CTS system (SDR 11 & SDR 13.5). These transition fittings are joined with one step solvent cement, which gives customer a very fast, efficient & simple solution to join both systems. Available sizes are from 15 mm (½") to 50 mm (2").



ENGINEERED WITH
ELEGANCE

FOR DEALERSHIP ENQUIRY

+91 85117 81111 customercare@astralbathware.com | www.astralbathware.com



*A consumer validated
Superbrand in piping
category for
consecutive 4 years*



*India's Most Trusted
Pipe Brand based on
TRA's Brand Trust
Report for the 5th time*

Power of Desire



*India's Most Desired
Brand based on
TRA's Brand Trust
Report 2022*



CIN NO: L25200GJ1996PLC029134

Registered & Corporate Office: Astral Limited

207/1, 'Astral House', B/h Rajpath Club, Off S. G. Highway, Ahmedabad - 380059.

Ph: +91-79 6621 2000 | Fax: +91-79 6621 2121 | E-mail: info@astralltd.com | Website: www.astralltd.com

For Export Inquiries: export@astralltd.com



ASTRAL TOLL FREE
1800 233 7957

Please get in touch with us between
10 AM to 6 PM between Monday to Friday
and the last Saturday of the month.
We will remain closed on Public Holidays.

SC: PR0700028
AAQ/PC/001
REV:07/23